

Rotary Table/ Rack & Pinion Type

Size: 10, 20, 30, 50

New

RoHS

Height

Max. **28%** reduction*¹

54 mm → **39 mm**

Reduced by **15 mm**

39 mm



Weight

Max. **28%** reduction*¹

940 g → **680 g**

*¹ Compared with the existing model (MSQ20)

Enlarged center
hole diameter for
piping

∅9 mm → ∅12 mm

Compared with the existing model
(MSQ20)



MSQ Series

SMC

CAT.ES20-256A

Compact and lightweight

Reduced Height

| Size | New MSQ (H1) | MSQ (H2) | Reduction rate [%] |
|------|--------------|----------|--------------------|
| 10 | 35.5 | 47 | 24 |
| 20 | 39 | 54 | 28 |
| 30 | 46 | 57 | 19 |
| 50 | 51.5 | 66 | 22 |

Reduced Weight

| Size | New MSQ | MSQ | Reduction rate [%] |
|------|---------|------|--------------------|
| 10 | 375 | 500 | 25 |
| 20 | 680 | 940 | 28 |
| 30 | 930 | 1230 | 24 |
| 50 | 1500 | 1990 | 25 |

* For the MSQ□A



2 types of cushions are available.



Cushion pad
Reduces the metal noise that occurs when the piston stops



Internal shock absorber
The maximum allowable kinetic energy is up to 5 times higher than the cushion pad.

| Size | Allowable kinetic energy [J] | |
|------|------------------------------|-------------------------|
| | Cushion pad | Internal shock absorber |
| 10 | 0.007 | 0.039 |
| 20 | 0.025 | 0.116 |
| 30 | 0.048 | 0.116 |
| 50 | 0.081 | 0.294 |

Improved workability

The end ports and the angle adjustment mechanisms are located on the same surface.

End ports

Angle adjustment mechanism (With cushion)

Side port (Same for the opposite side, With plug)

Internal shock absorber



3 types of mounting are possible.

Mounting dimensions are interchangeable with the existing MSQ series model. For mounting, refer to "Mounting" on page 25.

Top mounting (Through hole)

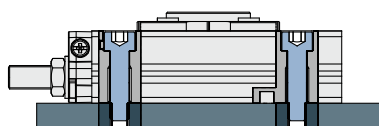
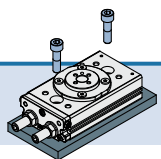

Bottom mounting (Body tapped)

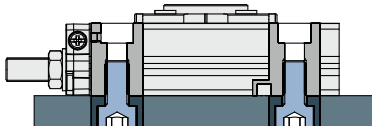
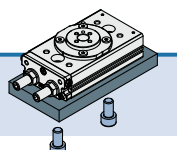

Top mounting (Body tapped)

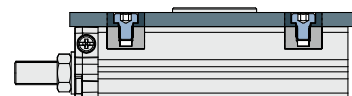
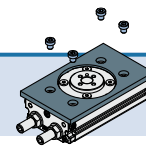

High durability and high accuracy

Large rolling bearing provides high durability and high accuracy.

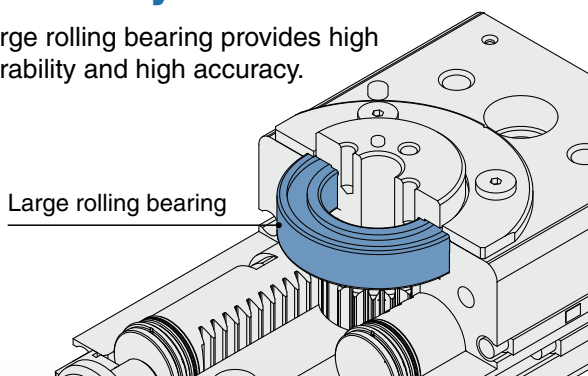

Enlarged center hole diameter for piping

| Size | New MSQ | MSQ |
|------|----------------|-----|
| 10 | ø7 | ø6 |
| 20 | ø12 | ø9 |
| 30 | ø13 | ø12 |
| 50 | ø14 | ø13 |

[mm]

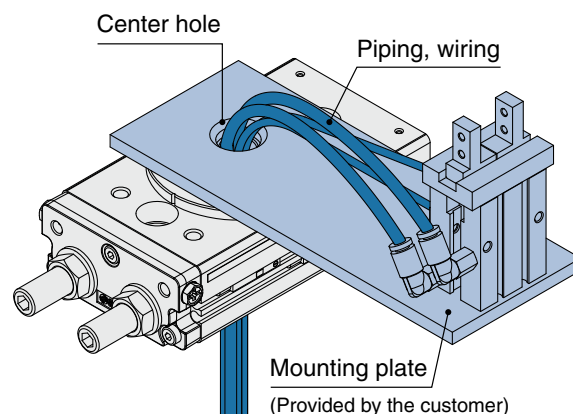
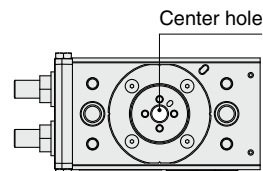

The adjustable rotation time range is expanded.

Can be used at lower speeds compared with the existing product

New MSQ: 0.2 to 2.0 s/90°

MSQ: 0.2 to 1.0 s/90°

* For the MSQ□A

Compact auto switches are mountable.



Solid state auto switch
D-M9□

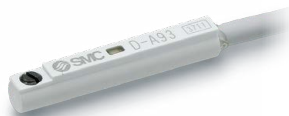

Reed auto switch
D-A9□

Interchangeable height tables and plates are available.

(Made to order)

The new product is only fully interchangeable with the existing product when the optional interchangeable plate and table are utilized.

* For details, refer to page 23.

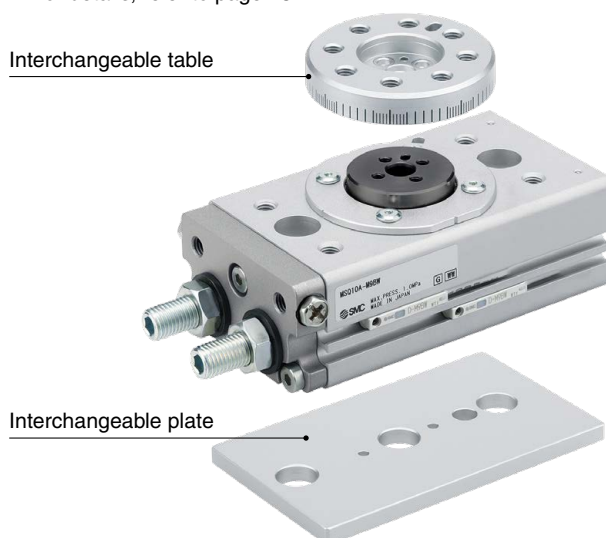

CONTENTS

Rotary Table/Rack & Pinion Type *MSQ Series*



| | |
|---|-------|
| Model Selection | p. 4 |
| How to Order | p. 15 |
| Specifications | p. 16 |
| Allowable Kinetic Energy and Rotation Time Adjustment Range | p. 16 |
| Weight | p. 16 |
| Rotation Direction and Rotating Angle | p. 17 |
| Rotating Angle Range Examples | p. 17 |
| Table Displacement (Reference values) | p. 18 |
| Working Principle | p. 18 |
| Construction | p. 19 |
| Dimensions | p. 20 |
| Auto Switch Mounting | p. 21 |
| Prior to Use | p. 22 |
| ● Made to Order | |
| With Interchangeable Table and Plate/ MSQ□-A | p. 23 |
| With Interchangeable Table/ MSQ□-B | p. 23 |
| With Interchangeable Plate/ MSQ□-C | p. 23 |
| Specific Product Precautions | p. 24 |

Rotary Actuator Model Selection

CONTENTS

| | | |
|----------|--|--------------|
| 1 | Calculation of Moment of Inertia | p. 6 |
| | ● Equation Table of Moment of Inertia | p. 6 |
| | ● Calculation Example of Moment of Inertia | p. 7 |
| | ● Graph for Calculating the Moment of Inertia | p. 9 |
| 2 | Calculation of Required Torque | p. 10 |
| | ● Load Type | p. 10 |
| | ● Effective Torque | p. 10 |
| 3 | Confirmation of Rotation Time | p. 10 |
| 4 | Calculation of Kinetic Energy | p. 11 |
| | ● Allowable Kinetic Energy and Rotation Time Adjustment Range | p. 11 |
| | ● Moment of Inertia and Rotation Time | p. 12 |
| 5 | Confirmation of Allowable Load | p. 12 |
| 6 | Calculation of Air Consumption and Required Air Flow Capacity | p. 13 |
| | ● Air Consumption Calculation Graph | p. 14 |

Rotary Actuator Model Selection

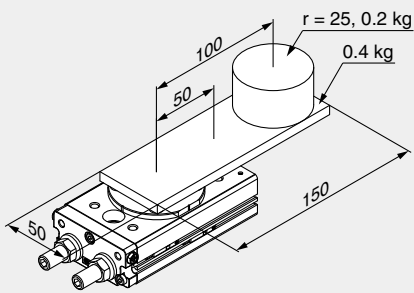
| Selection Procedures | Note | Selection Example |
|--|---|--|
| <p>◆ List of Operating Conditions</p> <ul style="list-style-type: none"> Initially selected models Operating pressure [MPa] Mounting orientation Load type <ul style="list-style-type: none"> Static load Resistance load Inertial load Load dimensions [m] Load mass [kg] Rotation time [s] Rotating angle [rad] | <p>Refer to page 10 for the load type.</p> <p>The unit for the rotating angle is radian. $180^\circ = \pi \text{ rad}$ $90^\circ = \pi/2 \text{ rad}$</p> |  <p>Initially selected model: MSQ30A Operating pressure: 0.3 MPa Mounting orientation: Vertical Load type: Inertial load Rotation time: $t = 1.5 \text{ s}$ Rotating angle: $\theta = \pi \text{ rad (180}^\circ)$</p> |
| 1 Calculation of Moment of Inertia | | |
| <p>Calculate the inertial moment of load.</p> <p>⇒ p. 6</p> | <p>Loads are generated from multiple parts. The inertial moment of each load is calculated, and then totaled.</p> | <p>Inertial moment of load 1: I_1</p> $I_1 = 0.4 \times \frac{0.15^2 + 0.05^2}{12} + 0.4 \times 0.05^2 = 0.001833$ <p>Inertial moment of load 2: I_2</p> $I_2 = 0.2 \times \frac{0.025^2}{2} + 0.2 \times 0.1^2 = 0.002063$ <p>Total inertial moment: I</p> $I = I_1 + I_2 = 0.003896 \text{ [kg}\cdot\text{m}^2]$ |
| 2 Calculation of Required Torque | | |
| <p>Calculate the required torque for each load type and confirm whether the values fall in the effective torque range.</p> <ul style="list-style-type: none"> Static load (T_s) Required torque $T = T_s$ Resistance load (T_f) Required torque $T = T_f \times (3 \text{ to } 5)$ Inertial load (T_a) Required torque $T = T_a \times 10$ <p>⇒ p. 10</p> | <p>When the resistance load is rotated, the required torque calculated from the inertial load must be added.</p> <p>Required torque $T = T_f \times (3 \text{ to } 5) + T_a \times 10$</p> | <p>Inertial load: T_a</p> $T_a = I \cdot \dot{\omega}$ $\dot{\omega} = \frac{2\theta}{t^2} \text{ [rad/s}^2]$ <p>Required torque: T</p> $T = T_a \times 10$ $= 0.003896 \times \frac{2 \times \pi}{1.5^2} \times 10 = 0.109 \text{ [N}\cdot\text{m]}$ <p>$0.109 \text{ N}\cdot\text{m} < \text{Effective torque OK}$</p> |
| 3 Confirmation of Rotation Time | | |
| <p>Confirm whether the time falls in the rotation time adjustment range.</p> <p>⇒ p. 10</p> | <p>Consider the time after converted in the time per 90°. $(1.0 \text{ s}/180^\circ \text{ is converted in } 0.5 \text{ s}/90^\circ.)$</p> | <p>$0.2 \leq t \leq 2.0$ $t = 0.75 \text{ s}/90^\circ \text{ OK}$</p> |
| 4 Calculation of Kinetic Energy | | |
| <p>Calculate the kinetic energy of the load and confirm whether the energy is below the allowable range.</p> <p>Can confirm referring to the inertial moment and rotation time graph (p. 12)</p> <p>⇒ p. 11</p> | <p>If the energy exceeds the allowable range, a suitable cushioning mechanism such as a shock absorber must be externally installed.</p> | <p>Kinetic energy: E</p> $E = \frac{1}{2} \cdot I \cdot \omega^2$ $\omega = \frac{2 \cdot \theta}{t}$ $E = \frac{1}{2} \times 0.003896 \times \left(\frac{2 \times \pi}{1.5}\right)^2 = 0.03418 \text{ [J]}$ <p>$0.03418 \text{ [J]} < \text{Allowable energy OK}$</p> |
| 5 Confirmation of Allowable Load | | |
| <p>Confirm whether the load applied to the product is within the allowable range.</p> <p>⇒ p. 12</p> | <p>If the load exceeds the allowable range, a bearing or similar must be externally installed.</p> | <p>Moment load: M</p> $M = 0.4 \times 9.8 \times 0.05 + 0.2 \times 9.8 \times 0.1$ $= 0.392 \text{ [N}\cdot\text{m]}$ <p>$0.392 \text{ [N}\cdot\text{m]} < \text{Allowable moment load OK}$</p> |
| 6 Calculation of Air Consumption and Required Air Flow Capacity | | |
| <p>Air consumption and required air flow capacity are calculated when necessary. ⇒ p. 13</p> | | |

1 Calculation of Moment of Inertia

The moment of inertia is a value indicating the inertia of a rotating body, and expresses the degree to which the body is difficult to rotate, or difficult to stop.

It is necessary to know the moment of inertia of the load in order to determine the value of required torque or kinetic energy when selecting a rotary actuator.

Moving the load with the actuator creates kinetic energy in the load. When stopping the moving load, it is necessary to absorb the kinetic energy of the load with a stopper or a shock absorber.

The kinetic energy of the load can be calculated using the formulas shown in **Fig. 1** (for linear motion) and **Fig. 2** (for rotation motion).

In the case of the kinetic energy for linear motion, the formula (1) shows that when the velocity **V** is constant, it is proportional to the mass **m**. In the case of rotation motion, the formula (2) shows that when the angular velocity ω is constant, it is proportional to the moment of inertia.

Linear motion

Fig. 1 Linear motion

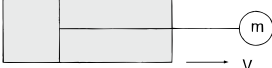

$$E = \frac{1}{2} \cdot m \cdot v^2 \dots\dots\dots (1)$$

E: Kinetic energy
m: Load mass
V: Velocity

Rotation motion

Fig. 2 Rotation motion

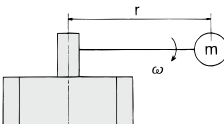

$$E = \frac{1}{2} \cdot I \cdot \omega^2 = \frac{1}{2} \cdot m \cdot r^2 \cdot \omega^2 \dots\dots\dots (2)$$

E: Kinetic energy
I: Moment of inertia (= $m \cdot r^2$)
 ω : Angular velocity
m: Mass
r: Radius of rotation

As the moment of inertia is proportional to the squares of the mass and the radius of rotation, even when the load mass is the same, the moment of inertia will be squared as the radius of rotation grows bigger. This will create greater kinetic energy, which may result in damage to the product.

When there is rotation motion, product selection should be based not on the load mass of the load, but on the moment of inertia.

Moment of Inertia Formula

The basic formula for obtaining a moment of inertia is shown below.

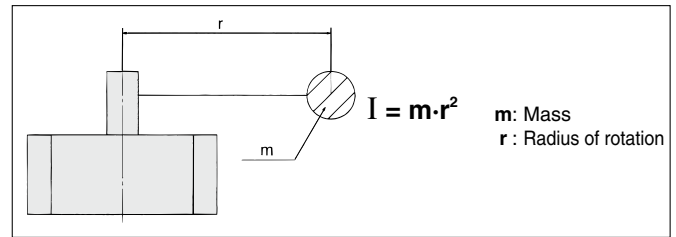

This formula represents the moment of inertia for the shaft with mass **m**, which is located at distance **r** from the shaft.

For actual loads, the values of the moment of inertia are calculated depending on configurations, as shown below.

- ⇒ p. 7, 8 Calculation example of moment of inertia
- ⇒ p. 9 Graph for calculating the moment of inertia

Equation Table of Moment of Inertia

I: Moment of inertia m: Load mass

1. Thin shaft

Position of rotational axis: Perpendicular to the shaft through the center of gravity

$$I = m \cdot \frac{a^2}{12}$$

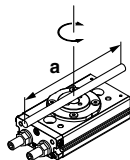

2. Thin rectangular plate

Position of rotational axis: Parallel to side **b** and through the center of gravity

$$I = m \cdot \frac{a^2}{12}$$

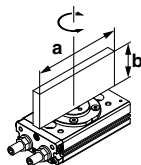

3. Thin rectangular plate (Including rectangular parallelepiped)

Position of rotational axis: Perpendicular to the plate through the center of gravity

$$I = m \cdot \frac{a^2 + b^2}{12}$$

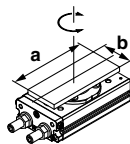

4. Round plate (Including column)

Position of rotational axis: Through the center axis

$$I = m \cdot \frac{r^2}{2}$$

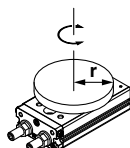

5. Solid sphere

Position of rotational axis: Through the center of diameter

$$I = m \cdot \frac{2r^2}{5}$$

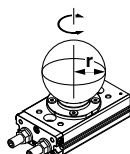

6. Thin round plate

Position of rotational axis: Through the center of diameter

$$I = m \cdot \frac{r^2}{4}$$

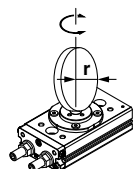

7. Cylinder

Position of rotational axis: Through the center of diameter and gravity

$$I = m \cdot \frac{3r^2 + a^2}{12}$$

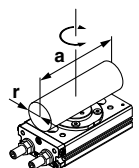

8. When the rotational axis and load center of gravity are not consistent

$$I = K + m \cdot L^2$$

K: Moment of inertia around the load center of gravity

4. Round plate $K = m \cdot \frac{r^2}{2}$

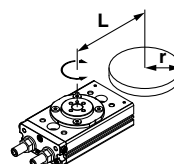

9. Gear transmission

1. Find the moment of inertia **I_B** for the rotation of shaft (B).

2. **I_B** is converted to the moment of inertia **I_A** for the rotation of the shaft (A).

$$I_A = \left(\frac{a}{b}\right)^2 \cdot I_B$$

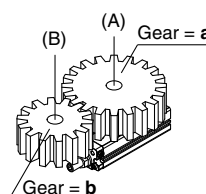

Rotary Actuator Model Selection

● Calculation Example of Moment of Inertia

■ If the shaft is located at a desired point of the load:

Example: ① If the load is the thin rectangular plate:
Obtain the center of gravity of the load as I_1 , a provisional shaft.

$$I_1 = m \cdot \frac{a^2 + b^2}{12}$$

② Obtain the actual moment of inertia I_2 around the shaft, with the premise that the mass of the load itself is concentrated in the load's center of gravity point.

$$I_2 = m \cdot L^2$$

③ Obtain the actual moment of inertia I .

$$I = I_1 + I_2$$

(m : Load mass
 L : Distance from the shaft to the load's center of gravity)

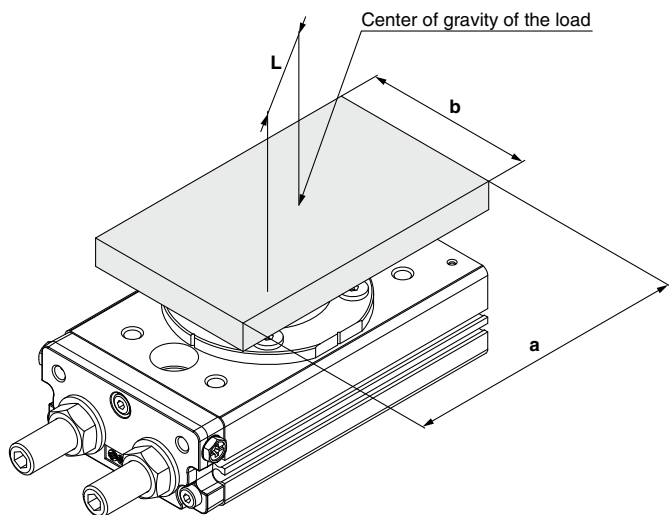

Calculation Example

$$a = 0.2 \text{ m}, b = 0.1 \text{ m}, L = 0.05 \text{ m}, m = 1.5 \text{ kg}$$

$$I_1 = 1.5 \times \frac{0.2^2 + 0.1^2}{12} = 6.25 \times 10^{-3} \text{ kg}\cdot\text{m}^2$$

$$I_2 = 1.5 \times 0.05^2 = 3.75 \times 10^{-3} \text{ kg}\cdot\text{m}^2$$

$$I = (6.25 + 3.75) \times 10^{-3} = 0.01 \text{ kg}\cdot\text{m}^2$$

■ If the load is divided into multiple loads:

Example: ① If the load is divided into the 2 cylinders:
 { The center of gravity of load 1 matches the shaft
 { The center of gravity of load 2 differs from the shaft }
 Obtain the moment of inertia of load 1:

$$I_1 = m_1 \cdot \frac{r_1^2}{2}$$

② Obtain the moment of inertia of load 2:

$$I_2 = m_2 \cdot \frac{r_2^2}{2} + m_2 \cdot L^2$$

③ Obtain the actual moment of inertia I :

$$I = I_1 + I_2$$

(m_1, m_2 : Mass of loads 1 and 2
 r_1, r_2 : Radius of loads 1 and 2
 L : Distance from the shaft to the center of gravity of load 2)

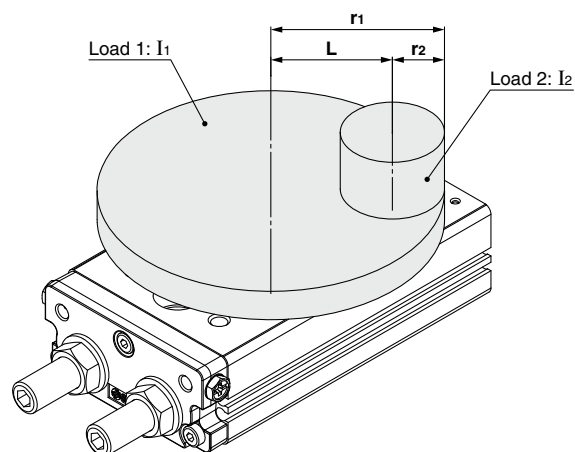

Calculation Example

$$m_1 = 2.5 \text{ kg}, m_2 = 0.5 \text{ kg}, r_1 = 0.1 \text{ m}, r_2 = 0.02 \text{ m}, L = 0.08 \text{ m}$$

$$I_1 = 2.5 \times \frac{0.1^2}{2} = 1.25 \times 10^{-2} \text{ kg}\cdot\text{m}^2$$

$$I_2 = 0.5 \times \frac{0.02^2}{2} + 0.5 \times 0.08^2 = 0.33 \times 10^{-2} \text{ kg}\cdot\text{m}^2$$

$$I = (1.25 + 0.33) \times 10^{-2} = 1.58 \times 10^{-2} \text{ kg}\cdot\text{m}^2$$

Rotary Actuator Model Selection

■ If a lever is attached to the shaft and a cylinder and a gripper are mounted to the tip of the lever:

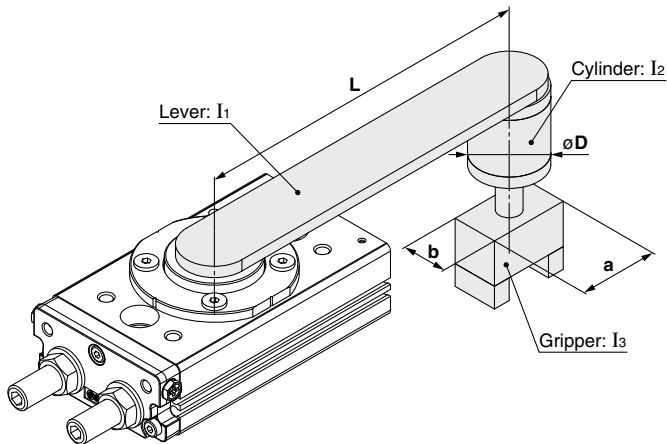

Example: ① Obtain the lever's moment of inertia:

$$I_1 = m_1 \cdot \frac{L^2}{3}$$

② Obtain the cylinder's moment of inertia:

$$I_2 = m_2 \cdot \frac{(D/2)^2}{2} + m_2 \cdot L^2$$

③ Obtain the gripper's moment of inertia:

$$I_3 = m_3 \cdot \frac{a^2 + b^2}{12} + m_3 \cdot L^2$$

④ Obtain the actual moment of inertia:

$$I = I_1 + I_2 + I_3$$

(m_1 : Mass of lever
 m_2 : Mass of cylinder
 m_3 : Mass of gripper)

Calculation Example

$L = 0.2 \text{ m}$, $\text{ø}D = 0.06 \text{ m}$, $a = 0.06 \text{ m}$, $b = 0.03 \text{ m}$, $m_1 = 0.5 \text{ kg}$, $m_2 = 0.4 \text{ kg}$, $m_3 = 0.2 \text{ kg}$

$$I_1 = 0.5 \times \frac{0.2^2}{3} = 0.67 \times 10^{-2} \quad \text{kg} \cdot \text{m}^2$$

$$I_2 = 0.4 \times \frac{(0.06/2)^2}{2} + 0.4 \times 0.2^2 = 1.62 \times 10^{-2} \quad \text{kg} \cdot \text{m}^2$$

$$I_3 = 0.2 \times \frac{0.06^2 + 0.03^2}{12} + 0.2 \times 0.2^2 = 0.81 \times 10^{-2} \quad \text{kg} \cdot \text{m}^2$$

$$I = (0.67 + 1.62 + 0.81) \times 10^{-2} = 3.1 \times 10^{-2} \quad \text{kg} \cdot \text{m}^2$$

■ If a load is rotated through the gears:

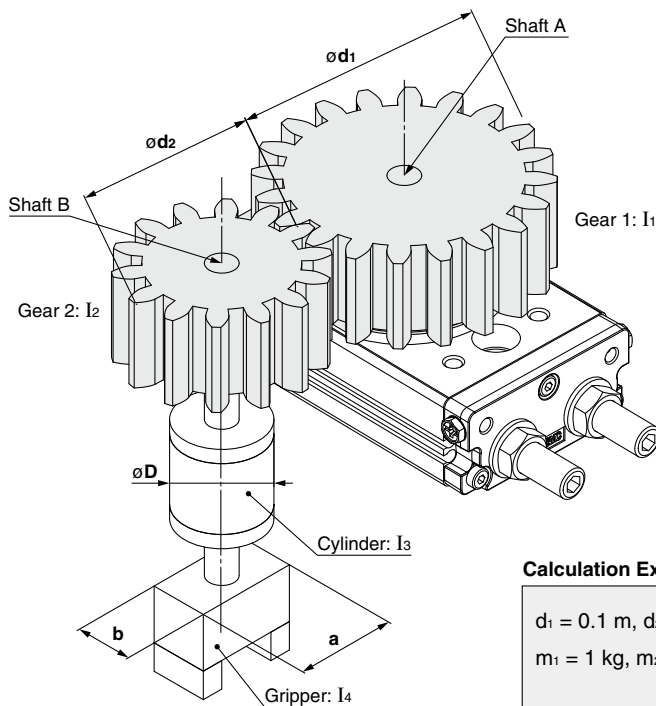

Example: ① Obtain the moment of inertia I_1 around shaft A:

$$I_1 = m_1 \cdot \frac{(d_1/2)^2}{2}$$

② Obtain moment of inertias I_2 , I_3 , and I_4 around shaft B:

$$I_2 = m_2 \cdot \frac{(d_2/2)^2}{2} \quad I_3 = m_3 \cdot \frac{(D/2)^2}{2}$$

$$I_4 = m_4 \cdot \frac{a^2 + b^2}{12} \quad I_B = I_2 + I_3 + I_4$$

③ Replace the moment of inertia I_B around shaft B with the moment of inertia I_A around shaft A.

$$I_A = (A/B)^2 \cdot I_B \quad [A/B: \text{Ratio of the number of teeth}]$$

④ Obtain the actual moment of inertia:

$$I = I_1 + I_A$$

(m_1 : Mass of gear 1
 m_2 : Mass of gear 2
 m_3 : Mass of cylinder
 m_4 : Mass of gripper)

Calculation Example

$d_1 = 0.1 \text{ m}$, $d_2 = 0.05 \text{ m}$, $D = 0.04 \text{ m}$, $a = 0.04 \text{ m}$, $b = 0.02 \text{ m}$

$m_1 = 1 \text{ kg}$, $m_2 = 0.4 \text{ kg}$, $m_3 = 0.5 \text{ kg}$, $m_4 = 0.2 \text{ kg}$, Ratio of the number of teeth = 2

$$I_1 = 1 \times \frac{(0.1/2)^2}{2} = 1.25 \times 10^{-3} \text{ kg} \cdot \text{m}^2$$

$$I_2 = 0.4 \times \frac{(0.05/2)^2}{2} = 0.13 \times 10^{-3} \text{ kg} \cdot \text{m}^2$$

$$I_3 = 0.5 \times \frac{(0.04/2)^2}{2} = 0.1 \times 10^{-3} \text{ kg} \cdot \text{m}^2$$

$$I_4 = 0.2 \times \frac{0.04^2 + 0.02^2}{12} = 0.03 \times 10^{-3} \text{ kg} \cdot \text{m}^2$$

$$I_B = (0.13 + 0.1 + 0.03) \times 10^{-3} = 0.26 \times 10^{-3} \text{ kg} \cdot \text{m}^2$$

$$I_A = 2^2 \times 0.26 \times 10^{-3} = 1.04 \times 10^{-3} \text{ kg} \cdot \text{m}^2$$

$$I = (1.25 + 1.04) \times 10^{-3} = 2.29 \times 10^{-3} \text{ kg} \cdot \text{m}^2$$

Rotary Actuator Model Selection

● Graph for Calculating the Moment of Inertia

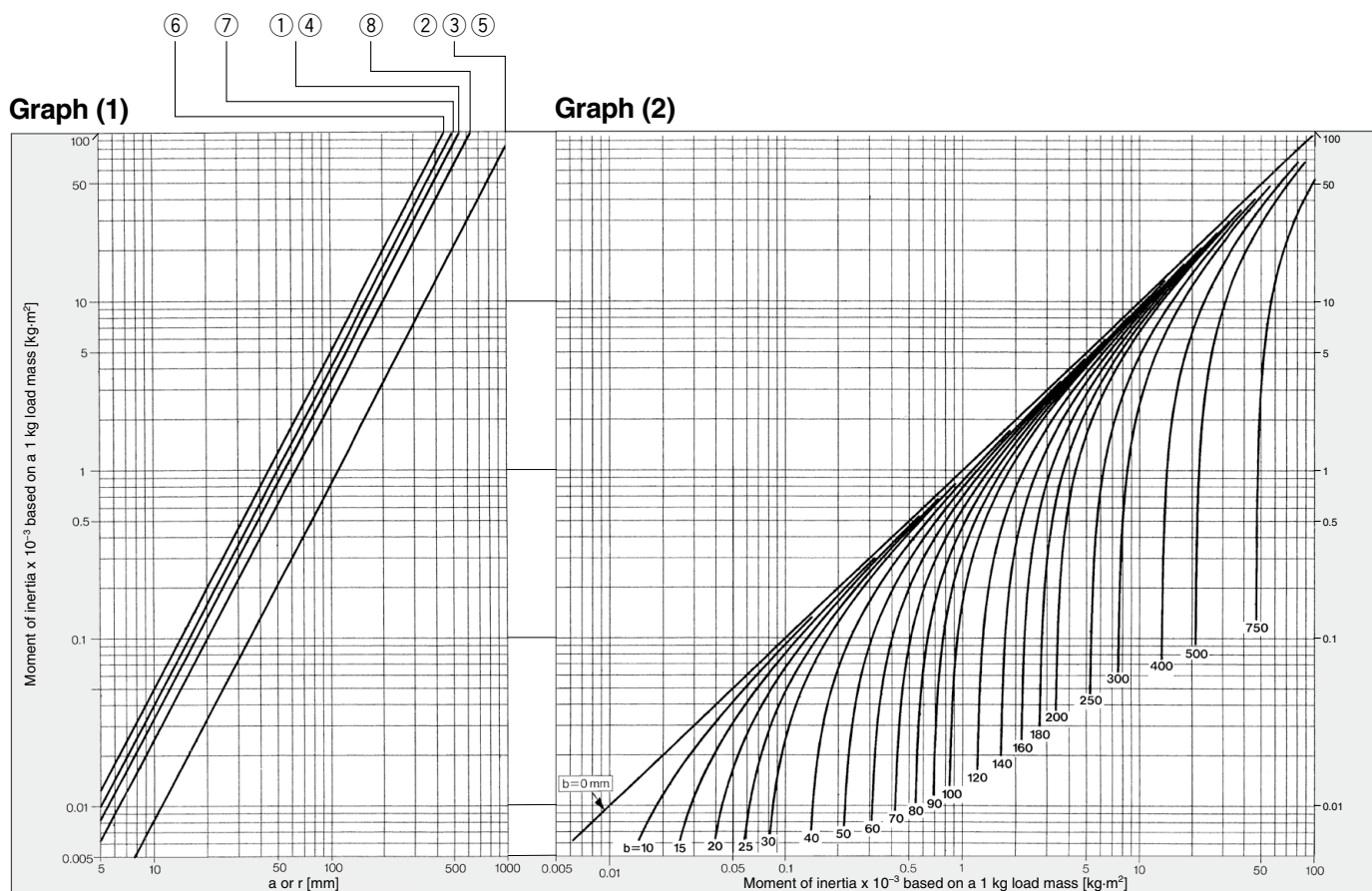
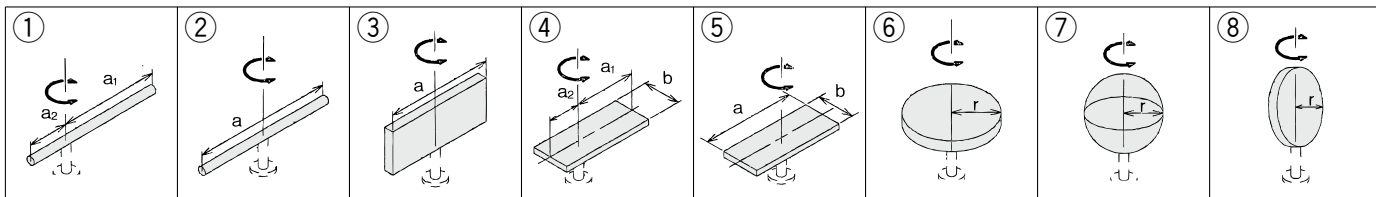

How to read the graph: Only when the dimension of the load is “a” or “r”

[Example] When the load shape is ②, $a = 100$ mm, and the load mass is 0.1 kg

In Graph (1), the point at which the vertical line of $a = 100$ mm and the line of the load shape ② intersect indicates that the moment of inertia of the 1 kg mass is $0.83 \times 10^{-3} \text{ kg}\cdot\text{m}^2$.

Since the load mass is 0.1 kg, the actual moment of inertia is $0.83 \times 10^{-3} \times 0.1 = 0.083 \times 10^{-3} \text{ kg}\cdot\text{m}^2$

(Note: If “a” is divided into “a1a2”, the moment of inertia can be obtained by calculating them separately.)

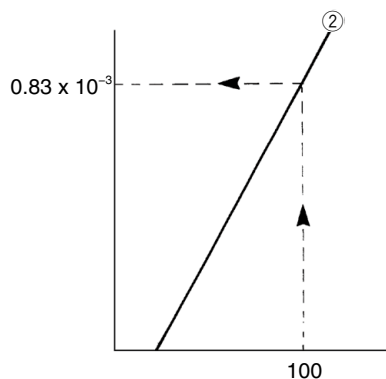

How to read the graph: When the dimension of the load contains both “a” and “b”

[Example] When the load shape is ⑤, $a = 100$ mm, $b = 100$ mm, and the load mass is 0.5 kg

In Graph (1), obtain the point at which the vertical line of $a = 100$ mm and the line of the load shape ⑤ intersect. Move this intersection point to Graph (2), and the point at which it intersects with the curve of $b = 100$ mm indicates that the moment of inertia of the 1 kg mass is $1.7 \times 10^{-3} \text{ kg}\cdot\text{m}^2$.

Since the load mass is 0.5 kg, the actual moment of inertia is $1.7 \times 10^{-3} \times 0.5 = 0.85 \times 10^{-3} \text{ kg}\cdot\text{m}^2$

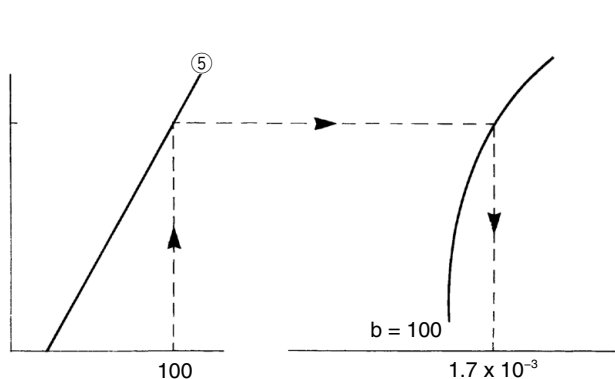

2 Calculation of Required Torque

● Load Type

The calculation method of required torque varies depending on the load type. Obtain the required torque referring to the table below.

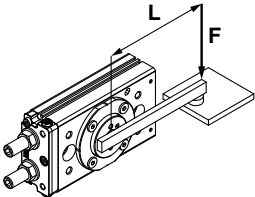
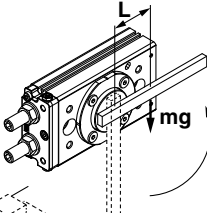
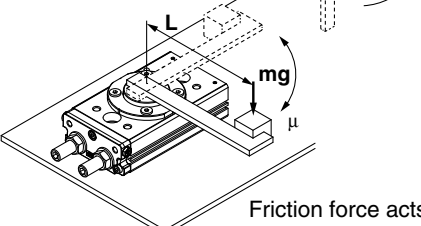
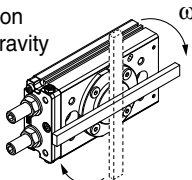
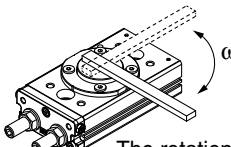
| Load type | | |
|---|---|--|
| Static load: T_s | Resistance load: T_f | Inertial load: T_a |
| When the pressing force is necessary (clamp, etc.) | When friction force or gravity is applied to the rotation direction | When the load with inertia is rotated |
|  | <p>Gravity acts</p>  <p>Friction force acts</p>  | <p>The center of rotation and the center of gravity are corresponding</p>  <p>The rotational axis is vertical (up and down)</p>  |
| $T_s = F \cdot L$ T_s : Static load [N·m] F : Clamp force [N] L : Distance from the center of rotation to clamp [m] | <p>When gravity acts to the rotation direction</p> $T_f = m \cdot g \cdot L$ <p>When friction force acts to the rotation direction</p> $T_f = \mu \cdot m \cdot g \cdot L$ T_f : Resistance load [N·m] m : Load mass [kg] g : Gravitational acceleration 9.8 [m/s ²] L : Distance from the center of rotation to the gravity or friction force acting point [m] μ : Coefficient of friction | $T_a = I \cdot \ddot{\omega} = I \cdot \frac{2\theta}{t^2}$ T_a : Inertial load [N·m] I : Moment of inertia [kg·m ²] $\ddot{\omega}$: Angular acceleration [rad/s ²] θ : Rotating angle [rad] t : Rotation time [s] |
| Required torque $T = T_s$ | Required torque $T = T_f \times (3 \text{ to } 5)^{*1}$ | Required torque $T = T_a \times 10^{*1}$ |
| <p>· Resistance loads → Gravity or friction applies in the rotation direction. Example 1) The axis of rotation is in a horizontal (lateral) direction, and the center of rotation and center of gravity of the load are not the same. Example 2) The load slips against the floor while rotating. * The required torque equals the total of the resistance load and inertial load. $T = T_f \times (3 \text{ to } 5) + T_a \times 10$</p> <p>· Non-resistance loads → Gravity or friction does not apply in the rotation direction. Example 1) The axis of rotation is in a perpendicular (vertical) direction. Example 2) The axis of rotation is in a horizontal (lateral) direction, and the center of rotation and center of gravity of the load are the same. * The required torque equals the inertial load only. $T = T_a \times 10$</p> | | |

● Effective Torque

[N·m]

| Size | Operating pressure [MPa] | | | | | | | | | |
|------|--------------------------|------|------|------|------|------|------|------|------|------|
| | 0.1 | 0.2 | 0.3 | 0.4 | 0.5 | 0.6 | 0.7 | 0.8 | 0.9 | 1.0 |
| 10 | 0.18 | 0.36 | 0.53 | 0.71 | 0.89 | 1.07 | 1.25 | 1.42 | 1.60 | 1.78 |
| 20 | 0.37 | 0.73 | 1.10 | 1.47 | 1.84 | 2.20 | 2.57 | 2.93 | 3.29 | 3.66 |
| 30 | 0.55 | 1.09 | 1.64 | 2.18 | 2.73 | 3.19 | 3.82 | 4.37 | 4.91 | 5.45 |
| 50 | 0.93 | 1.85 | 2.78 | 3.71 | 4.64 | 5.57 | 6.50 | 7.43 | 8.35 | 9.28 |

3 Confirmation of Rotation Time

For stable operation, check that each product is used within the allowable rotation time range.

MSQ□A (Cushion pad): 0.2 to 2.0 s/90° MSQ□R (Internal shock absorber): 0.2 to 0.7 s/90°

Rotary Actuator Model Selection

4 Calculation of Kinetic Energy

Kinetic energy is generated when the load rotates. Kinetic energy applies on the product at the operating end as inertial force, and may cause the product to damage. In order to avoid this, the value of allowable kinetic energy is determined for each product. Find the kinetic energy of the load, and verify that it is within the allowable range for the product in use.

Kinetic Energy

Use the following formula to calculate the kinetic energy of the load.

$$E = \frac{1}{2} \cdot I \cdot \omega^2$$

E : Kinetic energy [J]
I : Moment of inertia [kg·m²]
ω : Angular velocity [rad/s]

⇒ p. 12 Moment of inertia and rotation time

Angular Velocity

$$\omega = \frac{2\theta}{t}$$

ω : Angular velocity [rad/s]
θ : Rotating angle [rad]
t : Rotation time [s]

To find the rotation time when kinetic energy is within the allowable range for the product, use the following formula.

When the angular velocity is $\omega = \frac{2\theta}{t}$

$$t \geq \sqrt{\frac{2 \cdot I \cdot \theta^2}{E}}$$

t : Rotation time [s]
I : Moment of inertia [kg·m²]
θ : Rotating angle [rad]
E : Allowable kinetic energy [J]

● Allowable Kinetic Energy and Rotation Time Adjustment Range

Table: Allowable Kinetic Energy and Rotation Time Adjustment Range

| Size | Allowable kinetic energy [J] | | Adjustable range of rotation time safe in operation [s/90°] | |
|-----------|------------------------------|-------------------------|---|-------------------------|
| | Cushion pad | Internal shock absorber | Cushion pad | Internal shock absorber |
| 10 | 0.007 | 0.039 | 0.2 to 2.0 | 0.2 to 0.7 |
| 20 | 0.025 | 0.116 | | |
| 30 | 0.048 | 0.116 | | |
| 50 | 0.081 | 0.294 | | |

Calculation Example

Load form: Round rod
 Length of **a**₁ part : 0.12 m Rotating angle: 90°
 Length of **a**₂ part : 0.04 m Rotation time : 0.9^{s/90°}
 Mass of **a**₁ part (= **m**₁): 0.09 kg
 Mass of **a**₂ part (= **m**₂): 0.03 kg

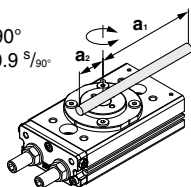

$$I = m_1 \cdot \frac{a_1^2}{3} + m_2 \cdot \frac{a_2^2}{3}$$

(Step 1) Find the angular velocity ω .

$$\omega = \frac{2\theta}{t} = \frac{2}{0.9} \left(\frac{\pi}{2} \right) = 3.489 \text{ rad/s}$$

(Step 2) Find the moment of inertia **I**.

$$I = \frac{m_1 \cdot a_1^2}{3} + \frac{m_2 \cdot a_2^2}{3} = \frac{0.09 \times 0.12^2}{3} + \frac{0.03 \times 0.04^2}{3} = 4.48 \times 10^{-4} \text{ kg} \cdot \text{m}^2$$

(Step 3) Find the kinetic energy **E**.

$$E = \frac{1}{2} \cdot I \cdot \omega^2 = \frac{1}{2} \times 4.48 \times 10^{-4} \times 3.489^2 = 0.00273 \text{ J}$$

Calculation Example

If the model to be used has been determined, obtain the threshold rotation time in which the rotary actuator can be used in accordance with the allowable kinetic energy of that model.

Model used : MSQ50A (Cushion pad)
 Allowable kinetic energy: 0.081 J (Refer to the table above.)
 Load form : Refer to the figure below.
 Rotating angle : 90°

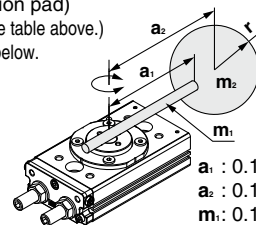

a₁ : 0.12 m
a₂ : 0.15 m
m₁ : 0.1 kg
m₂ : 0.18 kg
r : 0.03 m

$$I = m_1 \cdot \frac{a_1^2}{3} + m_2 \cdot a_2^2 + m_2 \cdot \frac{2r^2}{5}$$

(Step 1) Find the moment of inertia.

$$I = \frac{m_1 \cdot a_1^2}{3} + m_2 \cdot a_2^2 + \frac{m_2 \cdot 2r^2}{5} = \frac{0.1 \times 0.12^2}{3} + 0.18 \times 0.15^2 + \frac{0.18 \times 2 \times 0.03^2}{5} = 4.6 \times 10^{-3} \text{ kg} \cdot \text{m}^2$$

(Step 2) Find the rotation time.

$$t \geq \sqrt{\frac{2 \cdot I \cdot \theta^2}{E}} = \sqrt{\frac{2 \times 4.6 \times 10^{-3} \times (\pi/2)^2}{0.081}} = 0.53 \text{ s}$$

It is therefore evident that there will be no problem if it is used with a rotation time of less than 0.53 s. However, according to the table above, the maximum value of rotation time for stable operation is 2 s. Thus, the rotation time should be within the range of $0.53 \leq t \leq 2$.

● Moment of Inertia and Rotation Time

How to read the graph

Example 1) When there are constraints for the moment of inertia of load and rotation time. From Graphs (3) and (4), to operate at the load moment of inertia $1 \times 10^{-3} \text{ kg}\cdot\text{m}^2$ and at the rotation time setting of $0.3 \text{ s}/90^\circ$, the models will be MSQ50A and MSQ20 to 50R.

Example 2) When there are constraints for the moment of inertia of load, but not for rotation time. From Graphs (3) and (4), to operate at the load moment of inertia $1 \times 10^{-2} \text{ kg}\cdot\text{m}^2$:
 MSQ50A will be 0.8 to $2 \text{ s}/90^\circ$.
 MSQ50R will be 0.4 to $0.7 \text{ s}/90^\circ$.

[Remarks] As for the rotation times in Graphs (3) and (4), the lines in the graph indicate the adjustable speed ranges. If the speed is adjusted towards the low-speed end beyond the range of the line, it could cause the actuator to stick.

Graph (3) Cushion Pad

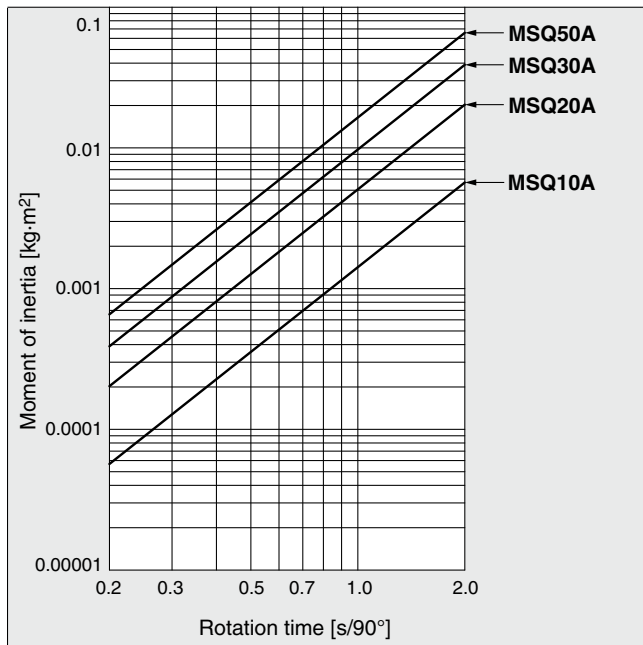

Graph (4) Internal Shock Absorber

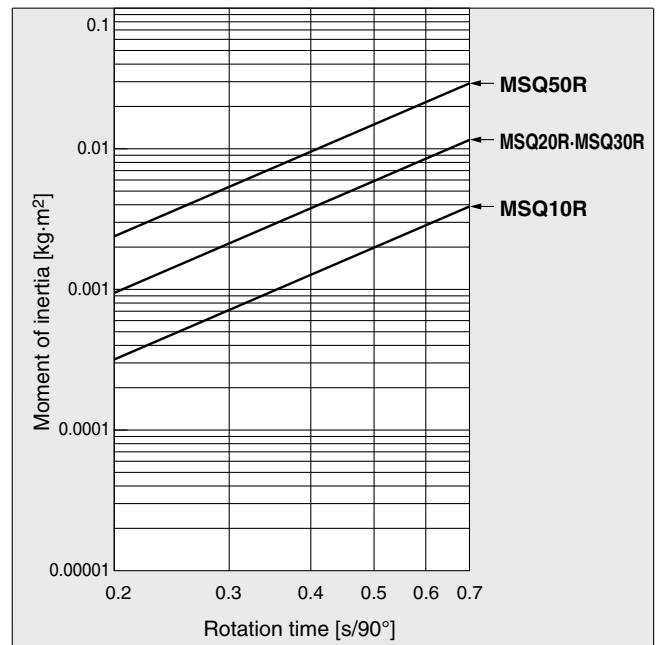

5 Confirmation of Allowable Load

Provided that a dynamic load is not generated, a load in the axial direction can be applied up to the value that is indicated in the table to the right. However, applications in which the load is applied directly to the shaft should be avoided as much as possible.

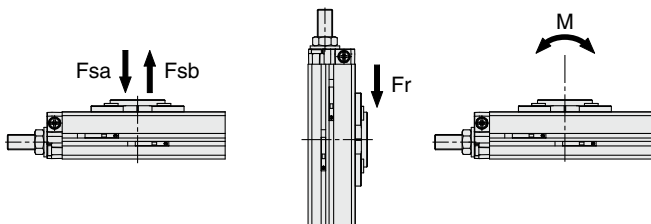

| Size | Load direction | | | |
|------|----------------|---------|--------|---------|
| | Fsa [N] | Fsb [N] | Fr [N] | M [N·m] |
| 10 | 78 | 74 | 78 | 2.4 |
| 20 | 137 | 137 | 147 | 4.0 |
| 30 | 363 | 197 | 196 | 5.3 |
| 50 | 451 | 296 | 314 | 9.7 |

Rotary Actuator Model Selection

6 Calculation of Air Consumption and Required Air Flow Capacity

Air consumption is the volume of air which is expended by the rotary actuator's reciprocal operation inside the actuator and in the piping between the actuator and the switching valve, etc. This is necessary for selection of a compressor and for calculation of its running cost. Required air volume is the air volume necessary to make a rotary actuator operate at a required speed. It requires calculation when selecting the upstream piping diameter from the switching valve and air line equipment.

* For the air consumption calculation graph, refer to Graphs (5) and (6) on page 14.

① Air consumption volume

Formula

$$Q_{CR} = V \times \left(\frac{P+0.1}{0.1} \right) \times 10^{-3} \dots\dots\dots (1)$$

$$Q_{CP} = 2 \times a \times L \times \left(\frac{P}{0.1} \right) \times 10^{-6} \dots\dots\dots (2)$$

$$Q_c = Q_{CR} + Q_{CP} \dots\dots\dots (3)$$

- Q_{CR} = Amount of air consumption of rotary actuator [L (ANR)]
- Q_{CP} = Amount of air consumption of tube or piping [L (ANR)]
- V = Inner volume of the rotary actuator (1 cycle) [cm³]
- P = Operating pressure [MPa]
- L = Length of piping [mm]
- a = Inner sectional area of piping [mm²]
- Q_c = Amount of air consumption required for one cycle of the rotary actuator [L (ANR)]

To select a compressor, it is important to select one that has plenty of margin to accommodate the total air volume that is consumed by the pneumatic actuators that are located downstream. The total air consumption volume is affected by the leakage in the tube, the consumption in the drain valves and pilot valves, as well as by the reduction in air volume due to reduced temperature.

Formula

$$Q_{c2} = Q_c \times n \times \text{No. of actuators} \times \text{Safety factor} \dots\dots (4)$$

- Q_{c2} = Amount of air from a compressor [L/min (ANR)]
- n = Actuator reciprocations per minute
- Safety factor: From 1.5

② Required air flow capacity

Formula

$$Q_r = \left\{ \frac{V}{2} \times \left(\frac{P+0.1}{0.1} \right) \times 10^{-3} + a \times L \times \left(\frac{P}{0.1} \right) \times 10^{-6} \right\} \times \frac{60}{t} \dots (5)$$

- Q_r = Consumed air volume for rotary actuator [L/min (ANR)]
- V = Inner volume of the rotary actuator (1 cycle) [cm³]
- P = Operating pressure [MPa]
- L = Length of piping [mm]
- a = Inner sectional area of piping [mm²]
- t = Total time for rotation [S]

Internal Cross Section of Tubing and Steel Tube

| Nominal | O.D. [mm] | I.D. [mm] | Internal cross section a [mm ²] |
|----------------|-----------|-----------|--|
| T□ 0425 | 4 | 2.5 | 4.9 |
| T□ 0604 | 6 | 4 | 12.6 |
| TU 0805 | 8 | 5 | 19.6 |
| T□ 0806 | 8 | 6 | 28.3 |

Rotary Actuator Model Selection

● Air Consumption Calculation Graph

Step 1 Using Graph (5), air consumption volume of the rotary actuator is obtained. From the point of intersection between the inner volume and the operating pressure (slanted line) and then looking to the side (left side) direction, the air consumption volume for 1 cycle operation of a rotary actuator is obtained.

Step 2 Using Graph (6), the air consumption volume for 1 cycle operation of tubing or steel tube is obtained.
 (1) First determine the point of intersection between the operating pressure (slanted line) and the piping length, and then go up the vertical line perpendicularly from there.
 (2) From the point of intersection of an operating piping tube inside diameter (slanted line), then look to the side (left or right) to obtain the required air consumption volume for piping.

Step 3 Total air consumption volume per minute is obtained as follows:
 (Air consumption volume of a rotary actuator [unit: L (ANR)] + Tubing or steel tube's air consumption volume) x Cycle times per minute x Number of rotary actuators = Total air consumption volume

Example) When 10 units of an MSQ30A are used at a pressure of 0.5 MPa, what is the air consumption of their 5 cycles per minute? (Piping between the actuator and switching valve is a tube with an inside diameter of 6 mm and length of 2 m.)

1. Operating pressure 0.5 MPa → Inner volume of MSQ30A 47.4 cm³ → Air consumption volume 0.25 L (ANR)
2. Operating pressure 0.5 MPa → Piping length 2 m → Inside diameter 6 mm → Air consumption volume 0.56 L (ANR)
3. Total air consumption volume = (0.25 + 0.56) x 5 x 10 = 40.5 L/min (ANR)

Graph (5) Air Consumption (1 cycle)

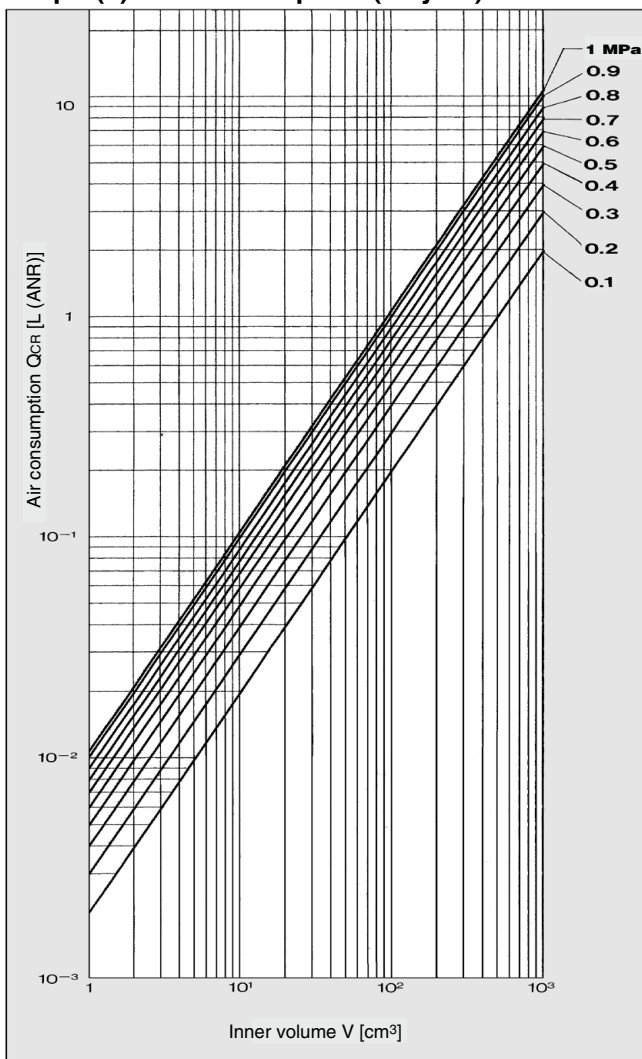

Inner Volume 1 cycle [cm³]

| Size | Rotating angle | |
|------|----------------|--|
| | 190° | |
| 10 | 15.6 | |
| 20 | 30.8 | |
| 30 | 47.4 | |
| 50 | 76.0 | |

Graph (6) Air Consumption of Tubing, Steel Tube (1 cycle)

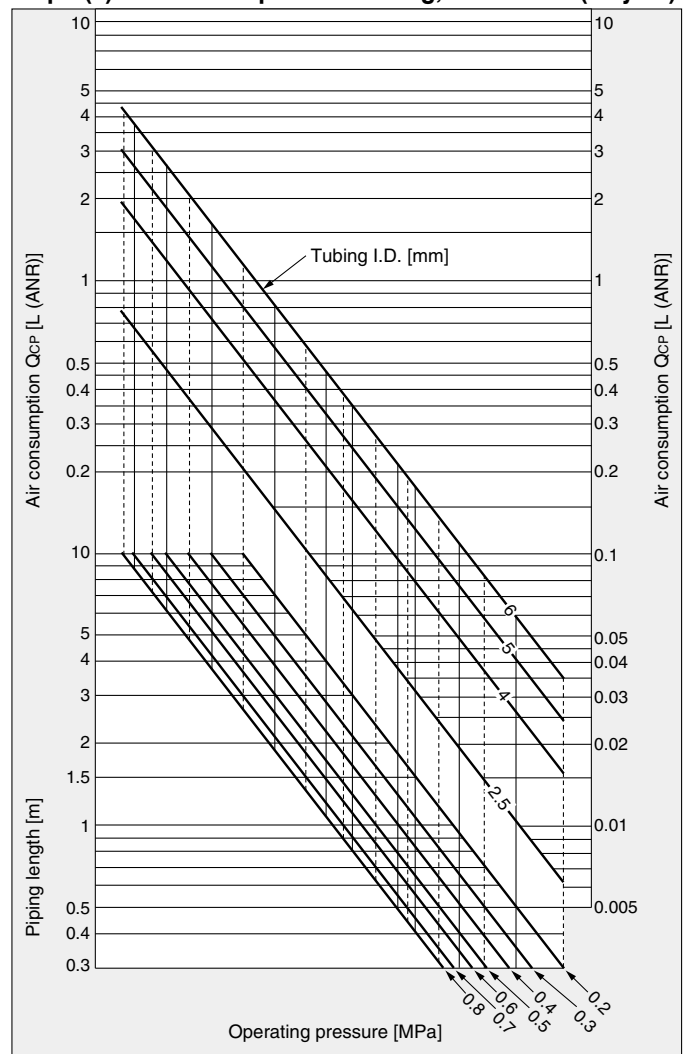

- * "Piping length" indicates the length of steel tube or tubing which connects rotary actuator and switching valves (solenoid valves, etc.).
- * Refer to page 13 for the size of tubing and steel tube (inside diameter and outside diameter).

Rotary Table/Rack & Pinion Type

MSQ Series



Size: 10, 20, 30, 50

How to Order

Basic type **MSQ 10 A - M9BW** [] [] - []

Size

| |
|----|
| 10 |
| 20 |
| 30 |
| 50 |

| | | |
|----------|-------------------------|--|
| A | Cushion pad |  |
| R | Internal shock absorber |  |

• Made to order
For details, refer to the next page.

• Port type

| End port type | | Size |
|---------------|--------|--------|
| Nil | M5 | 10, 20 |
| Nil | Rc1/8 | 30, 50 |
| -XF | G1/8 | |
| -XN | NPT1/8 | |

* Side ports are all M5.
For details, refer to the specifications on page 16.

• Number of auto switches

| | |
|------------|---|
| Nil | 2 |
| S | 1 |
| n | n |

• Auto switch

| | |
|------------|---------------------------------------|
| Nil | Without auto switch (Built-in magnet) |
|------------|---------------------------------------|

* For applicable auto switches, refer to the table below.

Applicable Auto Switches/Refer to the Web Catalog for further information on auto switches.

| Type | Special function | Electrical entry | Indicator light | Wiring (Output) | Load voltage | | Auto switch model | | Lead wire length [m] | | | | Pre-wired connector | Applicable load | | |
|-------------------------|------------------|------------------|-----------------|---------------------|--------------|-----------|------------------------|----------------|----------------------|-------|-------|-------|---------------------|-----------------|------------|------------|
| | | | | | DC | AC | Perpendicular | In-line | 0.5 (Nil) | 1 (M) | 3 (L) | 5 (Z) | | IC circuit | Relay, PLC | |
| Solid state auto switch | — | Grommet | Yes | 3-wire (NPN) | 24 V | 5 V, 12 V | — | M9NV | M9N | ● | ● | ● | ○ | ○ | IC circuit | Relay, PLC |
| | | | | 3-wire (PNP) | | | | M9PV | M9P | ● | ● | ● | ○ | ○ | IC circuit | |
| | | | | 2-wire | | | | M9BV | M9B | ● | ● | ● | ○ | ○ | — | |
| | 3-wire (NPN) | | | M9NWV | | | | M9NW | ● | ● | ● | ○ | ○ | IC circuit | | |
| | 3-wire (PNP) | | | M9PWV | | | | M9PW | ● | ● | ● | ○ | ○ | IC circuit | | |
| | 2-wire | | | M9BWV | | | | M9BW | ● | ● | ● | ○ | ○ | — | | |
| | 3-wire (NPN) | | | M9NAV *1 | | | | M9NA *1 | ○ | ○ | ● | ○ | ○ | IC circuit | | |
| | 3-wire (PNP) | | | M9PAV *1 | | | | M9PA *1 | ○ | ○ | ● | ○ | ○ | IC circuit | | |
| 2-wire | M9BAV *1 | M9BA *1 | ○ | ○ | ● | ○ | ○ | — | | | | | | | | |
| Reed auto switch | — | Grommet | Yes | 3-wire (NPN equiv.) | 24 V | 12 V | 100 V 100 V or less | A96V | A96 | ● | — | ● | — | — | IC circuit | — |
| | | | | 2-wire | | | | A93V *2 | A93 | ● | ● | ● | ● | — | — | Relay, PLC |
| | | | | | | | | A90V | A90 | ● | — | ● | — | — | — | IC circuit |

*1 Although it is possible to mount water-resistant type auto switches, note that the rotary actuator itself is not of water-resistant construction.

*2 The 1 m lead wire is only applicable to the D-A93.

* Lead wire length symbols: 0.5 m..... Nil (Example) M9NW
 1 m..... M (Example) M9NWM
 3 m..... L (Example) M9NWL
 5 m..... Z (Example) M9NWZ

* Solid state auto switches (marked with "○") are produced upon receipt of order.

* Auto switches are shipped together with the product but do not come assembled.

Specifications



Symbol

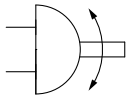

Made to Order
(For details, refer to page 23.)

| Symbol | Specifications |
|----------|--------------------------------------|
| A | With interchangeable table and plate |
| B | With interchangeable table |
| C | With interchangeable plate |

Refer to page 21 for models with auto switches.

· Auto Switch Proper Mounting Position
(at Rotation End Detection)

| Size | | 10 | 20 | 30 | 50 |
|---------------------------------------|--------------------------------|-------------------------|--------------|---------------------|-----|
| Fluid | | Air (Non-lube) | | | |
| Max. operating pressure | Cushion pad | 1 MPa | | | |
| | Internal shock absorber | 0.6 MPa*1 | | | |
| Min. operating pressure | | 0.1 MPa | | | |
| Ambient and fluid temperatures | | 0 to 60°C (No freezing) | | | |
| Cushion | Cushion pad | Rubber bumper | | | |
| | Internal shock absorber | Shock absorber | | | |
| | Shock absorber model | RBA0805 -X692 | RBA1006-X692 | RBA1411 -X692 | |
| Angle adjustment range *2 | | 0 to 190°*3 | | | |
| Max. rotating angle *2 | | 190° | | | |
| Cylinder bore size | | ø13 | ø16 | ø20 | ø22 |
| Port size | End port | M5 x 0.8 | | Rc1/8, G1/8, NPT1/8 | |
| | Side port | M5 x 0.8 | | | |

*1 The maximum operating pressure of the actuator is restricted by the maximum allowable thrust of the shock absorber.

*2 For details, refer to page 17.

*3 Be careful if the rotating angle of a type with internal shock absorber is set below the value in the table below, the piston stroke will be smaller than the shock absorber's effective stroke, resulting in decreased energy absorption ability.

| Size | 10 | 20 | 30 | 50 |
|--|-----|-----|-----|-----|
| Minimum rotating angle that will not allow decrease of energy absorption ability | 40° | 35° | 35° | 47° |

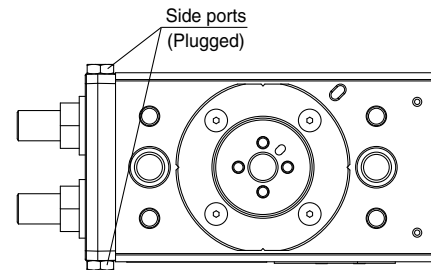
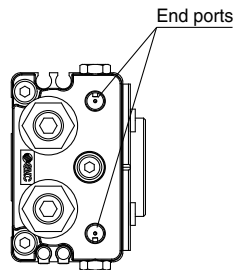

Allowable Kinetic Energy and Rotation Time Adjustment Range

| Size | Allowable kinetic energy [J]*1 | | Adjustable range of rotation time safe in operation [s/90°] | |
|-----------|--------------------------------|-------------------------|---|---------------------------|
| | Cushion pad | Internal shock absorber | Cushion pad | Internal shock absorber*2 |
| 10 | 0.007 | 0.039 | 0.2 to 2.0 | 0.2 to 0.7 |
| 20 | 0.025 | 0.116 | | |
| 30 | 0.048 | 0.116 | | |
| 50 | 0.081 | 0.294 | | |

*1 If operated where the kinetic energy exceeds the allowable value, this may cause damage to the internal parts and result in product failure. Please pay special attention to the kinetic energy levels when designing and during operation to avoid exceeding the allowable limit.

*2 When the rotation time of the type with an internal shock absorber is set longer than the time shown in the table above, energy absorption of the shock absorber greatly decreases.

Weight

| Size | | 10 | 20 | 30 | 50 |
|------------|-------------------------|-----|-----|------|------|
| Basic type | Cushion pad | 375 | 680 | 930 | 1500 |
| | Internal shock absorber | 440 | 795 | 1130 | 1810 |

* Values above do not include auto switch weight.

* For made-to-order options, add the weight in the table below to the weight of the base model.

| Size | 10 | 20 | 30 | 50 |
|--------------------------------------|----|-----|-----|-----|
| With interchangeable table and plate | 70 | 160 | 120 | 220 |
| With interchangeable table | 30 | 60 | 80 | 130 |
| With interchangeable plate | 40 | 100 | 40 | 90 |

Rotation Direction and Rotating Angle

- The rotary table turns in the counterclockwise direction where the A port is pressurized, and in the clockwise direction when the B port is pressurized. (Please note that the rotation direction is different from the existing MSQ.)
- By adjusting the adjustment bolt, the rotation end can be set within the ranges shown in the drawing.
- The rotating angle can also be set on a type with internal shock absorber.
- Refer to page 24 for the tightening torques for setting the rotating angle.

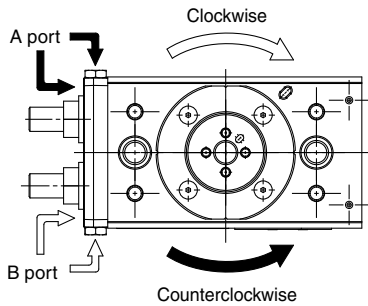

Adjustment bolt A
(For counterclockwise rotation end adjustment)

Adjustment bolt B
(For clockwise rotation end adjustment)

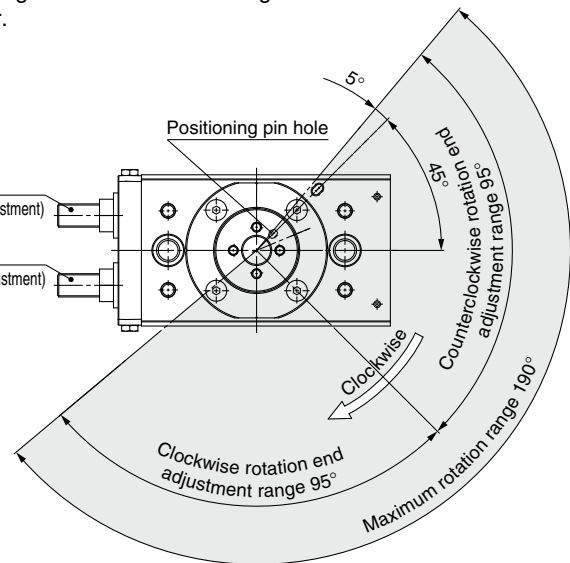

Rotation Direction and Rotating Angle (Cushion pad, Internal shock absorber)

| Size | Adjustment angle per rotation of adjustment bolt |
|------|--|
| 10 | 8.0° |
| 20 | 5.7° |
| 30 | 5.7° |
| 50 | 6.4° |

Rotating Angle Range Examples

- Various rotation ranges are possible as shown in the drawings below using adjustment bolts A and B. (The drawings also show the rotation ranges of the positioning pin hole.)
- The rotating angle can also be set on a type with internal shock absorber.

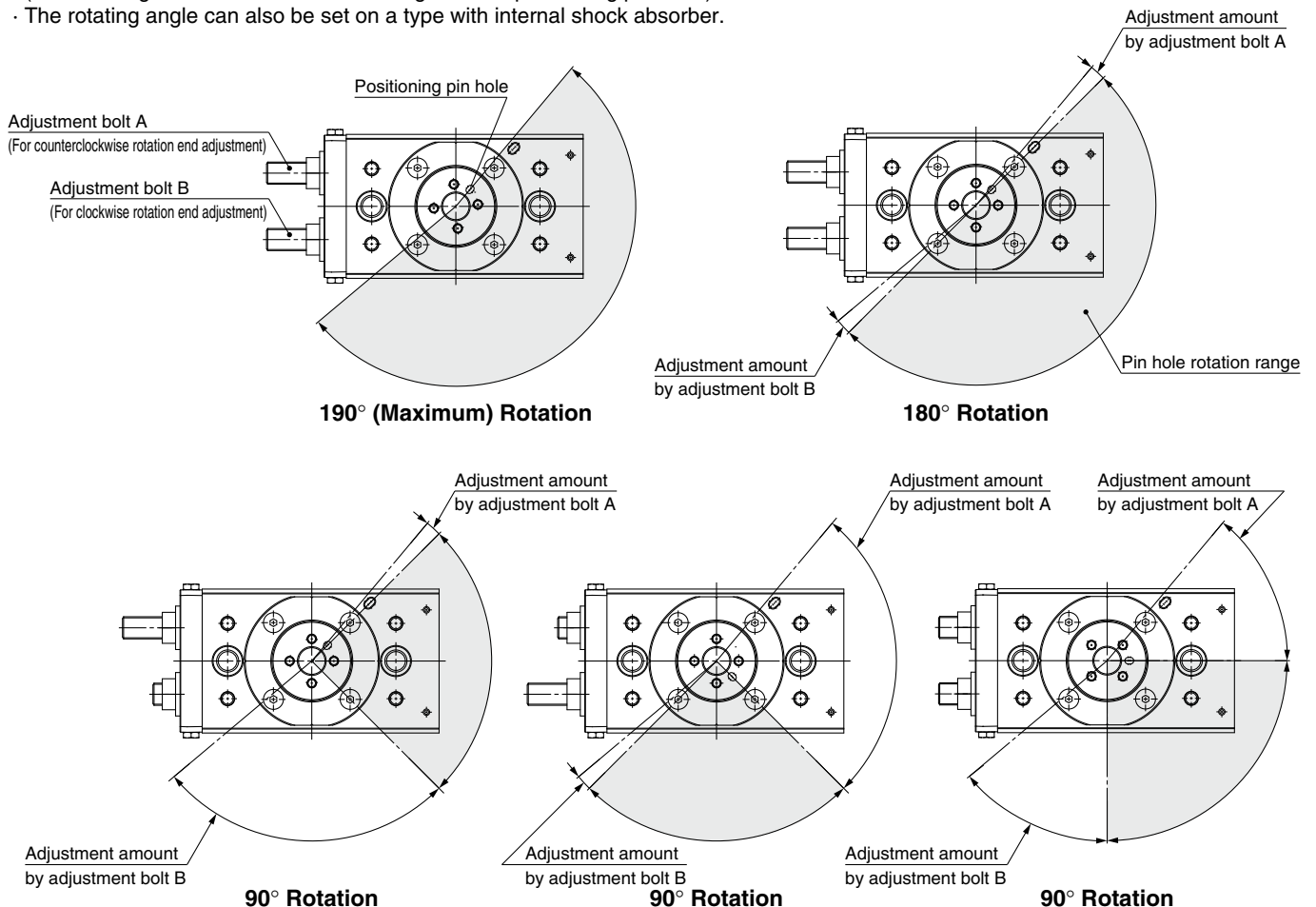
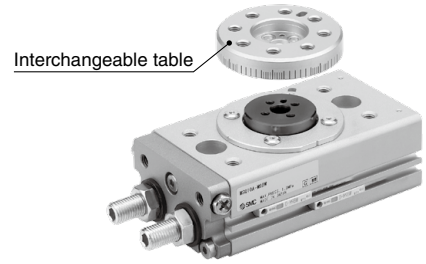
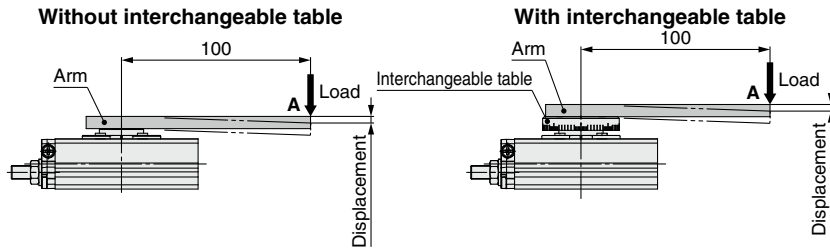
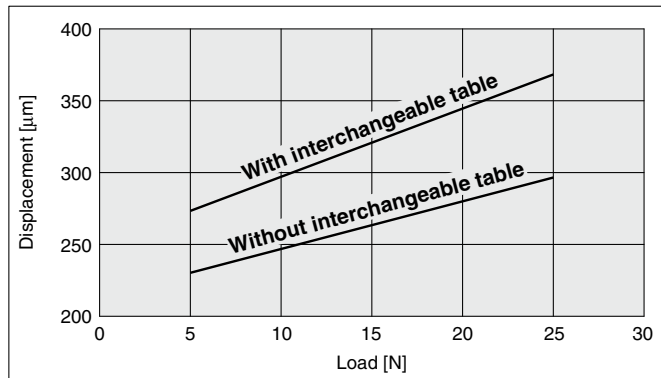

Table Displacement (Reference values)

The following graphs show the displacement at point A, which is 100 mm apart from the center of rotation, where the load is applied.



Size 10



Size 20

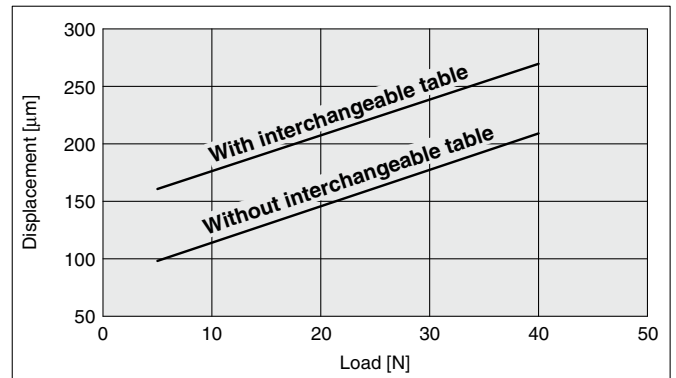

Size 30

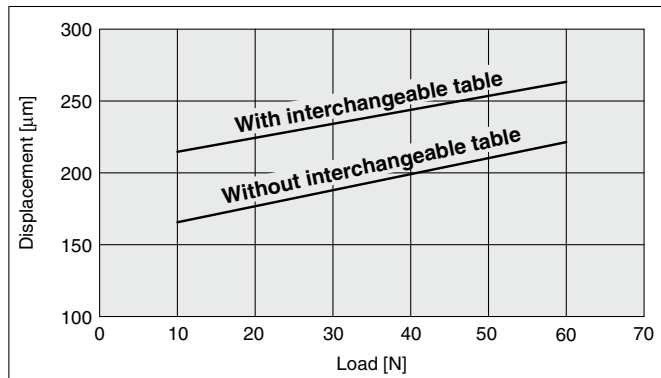

Size 50

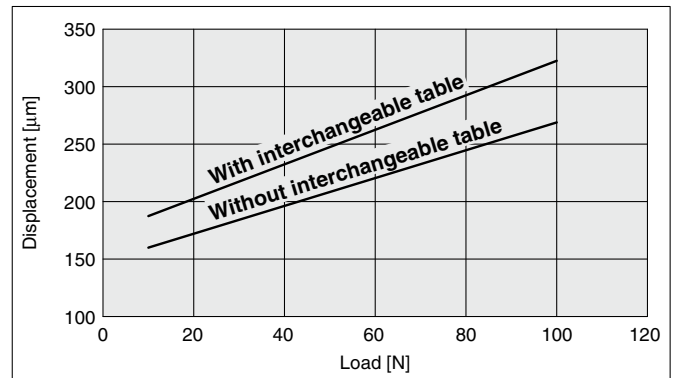

Working Principle

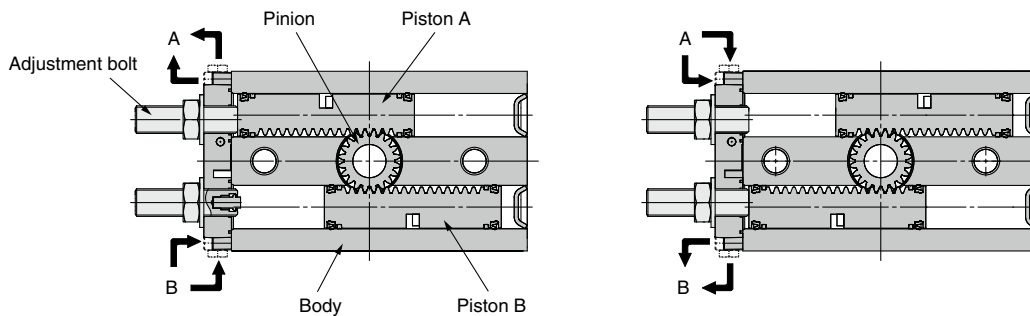

1. It consists of a rack that slides in 2 parallel cylinders, 2 pistons that are integrated with the rack, and a pinion.
2. The air that is supplied from port B pushes the left side of piston A; at the same time, it passes through the air passage of the body, pushing the right side of piston B, thus creating in the shaft an amount of torque that is equivalent to 2 pistons.
3. The air in the exhaust chamber discharges via port A and rotates clockwise.
4. The pinion stops when piston B comes in contact with the adjustment bolt and stops.
5. Similarly, when air is supplied from port A, it rotates counterclockwise.

MSQ Series

Construction

MSQ□R (With internal shock absorber)

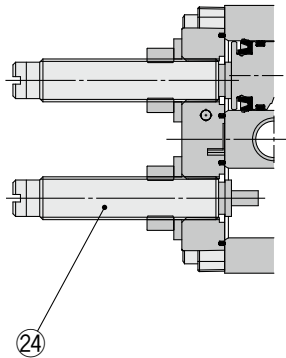

MSQ□A (Cushion pad)

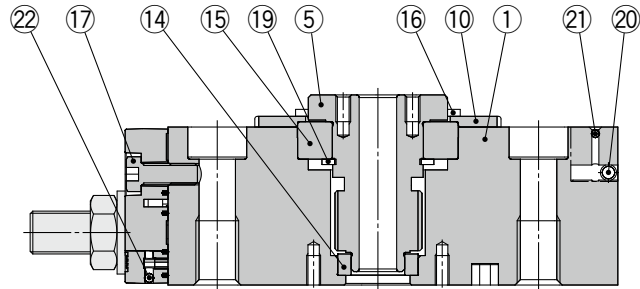
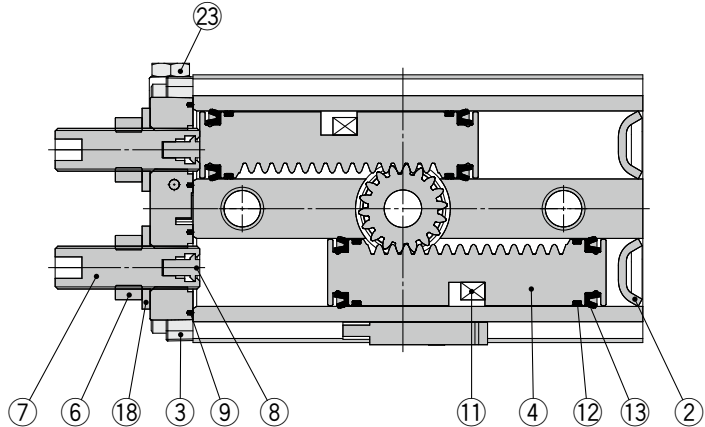

Component Parts

| No. | Description | Material | Note |
|-----|--|-------------------------|------------------|
| 1 | Body | Aluminum alloy | Anodized |
| 2 | Head cap | Aluminum alloy | Anodized |
| 3 | End cover | Aluminum alloy | Painted |
| 4 | Piston | Aluminum alloy | Anodized |
| | | Stainless steel | |
| 5 | Table pinion | Chrome molybdenum steel | |
| 6 | Compact hexagon nut | Steel wire | Chromated |
| 7 | Adjustment bolt | Chrome molybdenum steel | Chromated |
| 8 | Cushion pad | Rubber material | |
| 9 | Gasket | NBR | |
| 10 | Bearing retainer | Aluminum alloy | Anodized |
| 11 | Magnet | — | |
| 12 | Wear ring | Resin | |
| 13 | Piston seal | NBR | |
| 14 | Bearing | Bearing steel | |
| 15 | Bearing | Bearing steel | |
| 16 | Hexagon socket super thin head cap screw | Steel wire | Chromated |
| 17 | Hexagon socket thin head cap screw | Steel wire | Chromated |
| 18 | Seal washer | Steel wire + NBR | |
| 19 | Round type S retaining ring | Steel wire | Phosphate coated |
| 20 | Steel ball | Stainless steel | |
| 21 | Steel ball | Stainless steel | |
| 22 | Steel ball | Stainless steel | |
| 23 | M5 plug assembly | Steel wire | Nickel plating |
| 24 | Shock absorber | — | |

Replacement Parts

| Size | Part no. | Contents |
|------|-----------|--------------------|
| | | Description (Qty.) |
| 10 | P891010-5 | ⑨ Gasket (1) |
| 20 | P891020-5 | ⑫ Wear ring (4) |
| 30 | P891030-5 | ⑬ Piston seal (4) |
| 50 | P891040-5 | ⑯ Seal washer (2) |

A grease pack (10 g) is included. Order with the following part number when only the grease pack is needed.

Grease pack part number: GR-L-010 (10 g)

Dimensions: Sizes 10, 20, 30, 50

Basic type/MSQ□^A_R

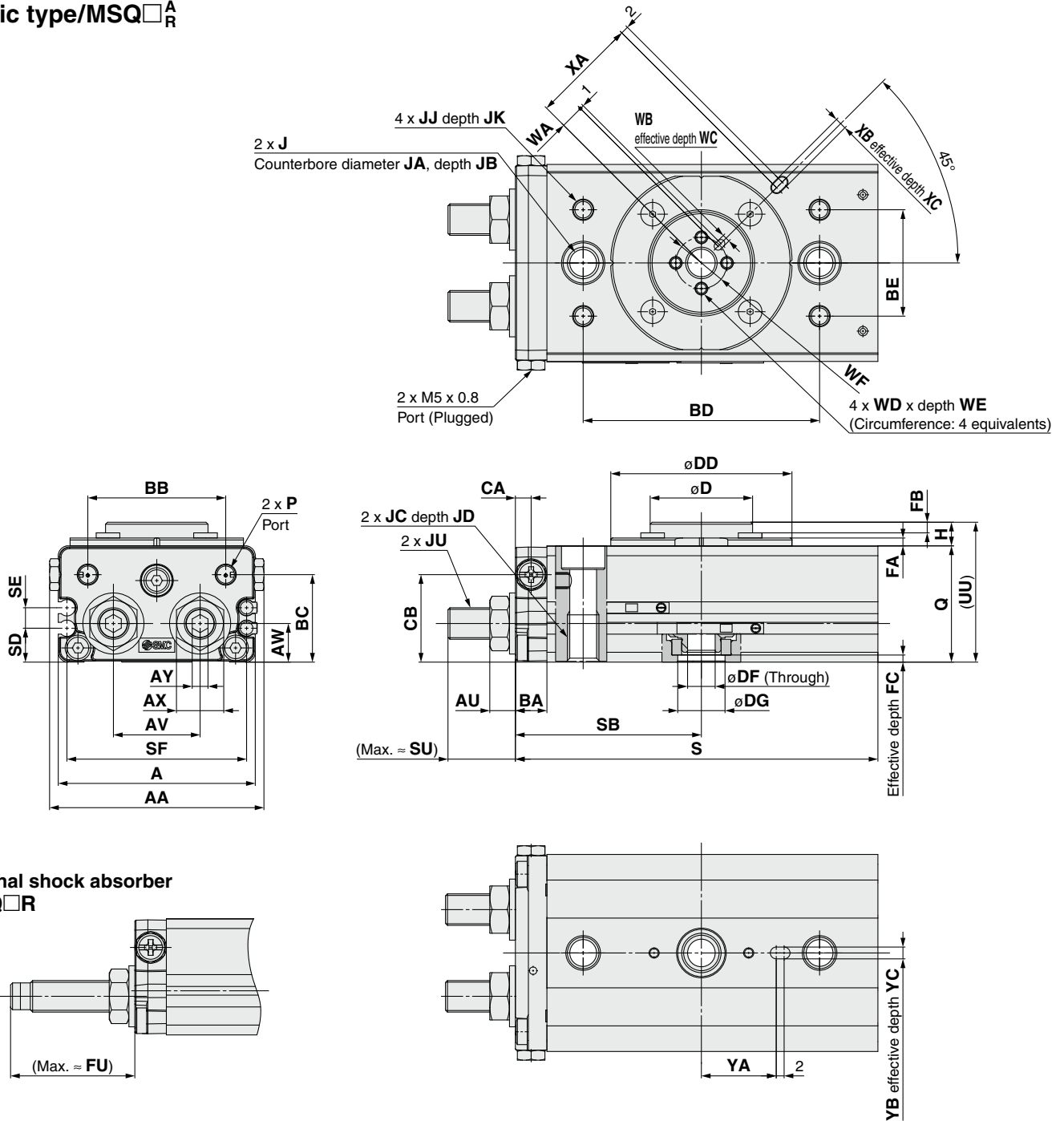

Internal shock absorber MSQ□_R

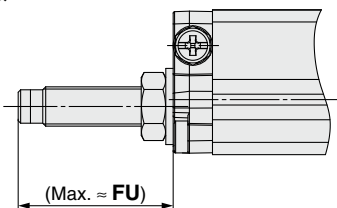

| Size | AA | A | AU | AV | AW | AX | AY | BA | BB | BC | BD | BE | CA | CB | D | DD | DF | DG | FA | FB | FC | FU | H | J | JA | JB | JC | JD |
|------|------|----|-----|------|------|----|----|----|------|------|-----|----|----|------|------|------|----|------|-----|-----|-----|----|-----|------|----|------|------------|----|
| 10 | 54.4 | 50 | 6.6 | 22 | 9.8 | 12 | 4 | 8 | 35 | 22.2 | 60 | 27 | 4 | 22.2 | 26h9 | 46h9 | 7 | 12H9 | 2 | 2.7 | 1.3 | 32 | 6 | 6.8 | 11 | 6 | M8 x 1.25 | 12 |
| 20 | 69.4 | 65 | 7.6 | 30 | 11.1 | 14 | 5 | 10 | 50.2 | 23.6 | 76 | 34 | 5 | 23.6 | 36h9 | 61h9 | 12 | 20H9 | 4 | 2.5 | 1.3 | 36 | 8 | 8.6 | 14 | 8.5 | M10 x 1.5 | 15 |
| 30 | 74.4 | 70 | 7.6 | 36.5 | 13.8 | 14 | 5 | 12 | 49 | 30 | 84 | 37 | 6 | 31 | 41h9 | 67h9 | 13 | 20H9 | 4 | 2.5 | 2.3 | 34 | 8 | 8.6 | 14 | 8.5 | M10 x 1.5 | 15 |
| 50 | 84.4 | 80 | 10 | 42 | 17.5 | 19 | 6 | 12 | 62 | 35 | 100 | 50 | 6 | 35 | 46h9 | 77h9 | 14 | 21H9 | 4.5 | 2.5 | 2.7 | 54 | 8.5 | 10.5 | 18 | 10.5 | M12 x 1.75 | 18 |

| Size | JJ | JK | JU | P | Q | S | SB | SD | SE | SF | SU*1 | UU | WA | WB | WC | WD | WE | WF | XA | XB | XC | YA | YB | YC |
|------|-----------|----|-----------|----------|------|-----|------|------|-----|------|------|------|------|-----|-----|----------|----|----|----|-----|-----|----|-----|-----|
| 10 | M5 x 0.8 | 6 | M8 x 1 | M5 x 0.8 | 29.5 | 92 | 47.2 | 8.6 | 5.2 | 45.6 | 18 | 35.5 | 6 | 2H9 | 2.5 | M3 x 0.5 | 5 | 13 | 27 | 3H9 | 3.5 | 19 | 3H9 | 3.5 |
| 20 | M6 x 1 | 6 | M10 x 1 | M5 x 0.8 | 31 | 117 | 59.9 | 10.1 | 5.2 | 59.4 | 26 | 39 | 9.5 | 3H9 | 3.5 | M4 x 0.7 | 7 | 20 | 36 | 4H9 | 4.5 | 24 | 4H9 | 4.5 |
| 30 | M6 x 1 | 6 | M10 x 1 | Rc1/8*2 | 38 | 127 | 65.3 | 10.3 | 14 | 65 | 24 | 46 | 10.5 | 4H9 | 3.5 | M5 x 0.8 | 9 | 22 | 39 | 4H9 | 4.5 | 28 | 4H9 | 4.5 |
| 50 | M8 x 1.25 | 8 | M14 x 1.5 | Rc1/8*2 | 43 | 152 | 77.7 | 11.3 | 16 | 75 | 34 | 51.5 | 11.5 | 4H9 | 3.5 | M6 x 1 | 10 | 24 | 45 | 5H9 | 5.5 | 33 | 5H9 | 5.5 |

*1 SU dimension is not the dimension at the time of shipment, since its dimension is for adjustment parts.

*2 In addition to Rc1/8, G1/8 and NPT1/8 are also available.

MSQ Series Auto Switch Mounting

Auto Switch Proper Mounting Position (at Rotation End Detection)

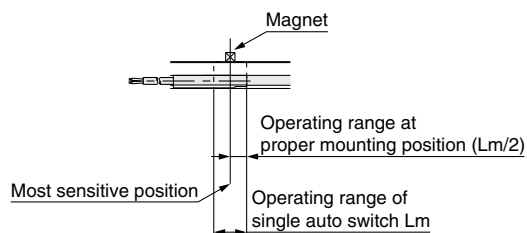
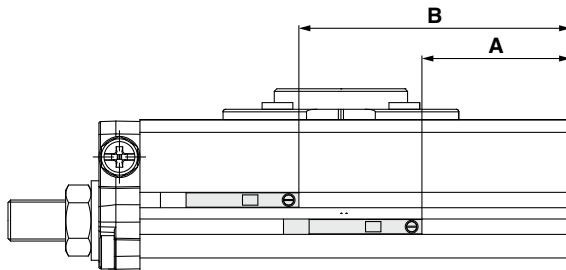
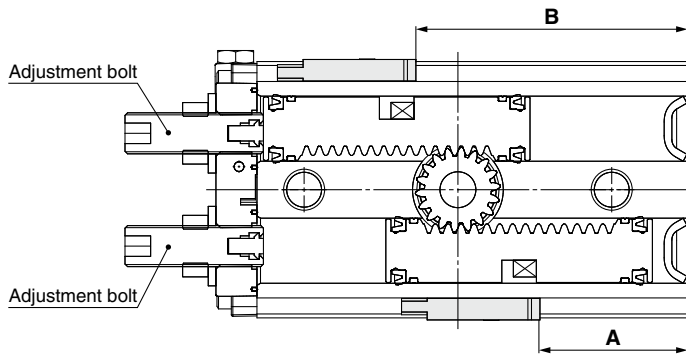

[mm]

| Size | Rotating angle | Solid state auto switch | | | | Reed auto switch | | | |
|------|----------------|-------------------------|----------|-------------------------------|------------------|------------------|----------|-------------------------------|------------------|
| | | D-M9□(V), D-M9□W(V) | | | | D-A9□, D-A9□V | | | |
| | | A | B | Operating angle θ_m | Hysteresis angle | A | B | Operating angle θ_m | Hysteresis angle |
| 10 | 180° | 26 to 29 | 49 to 51 | 27° | 3° | 22 to 25 | 45 to 47 | 50° | 4° |
| 20 | 180° | 34 to 37 | 66 to 68 | 21° | 2° | 30 to 33 | 62 to 64 | 42° | 4° |
| 30 | 180° | 39 to 41 | 70 to 73 | 24° | 2° | 35 to 37 | 66 to 69 | 44° | 4° |
| 50 | 180° | 46 to 48 | 88 to 91 | 19° | 2° | 42 to 44 | 84 to 87 | 31° | 3° |

Operating angle θ_m : Value of the operating range Lm of a single auto switch converted to an axial rotating angle

Hysteresis angle : Value of auto switch hysteresis converted to an angle

* : Since the figures in the table above are provided as a guideline only, they cannot be guaranteed. Adjust the auto switch after confirming the operating conditions in the actual setting.

· The values in the table above are the positions when the adjustment bolts (shock absorbers) are tightened in the same amount and adjusted to 180°.

· For the tightening torque of the set screw of the auto switch, refer to the operation manual of each auto switch.

Prior to Use

Auto Switch Connections and Examples

Sink Input Specifications

3-wire, NPN

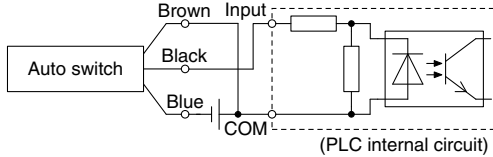

2-wire

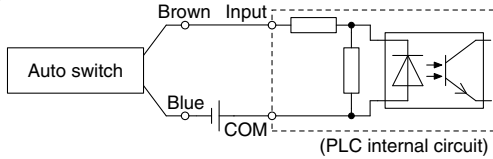

Source Input Specifications

3-wire, PNP

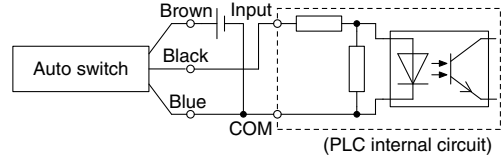

2-wire

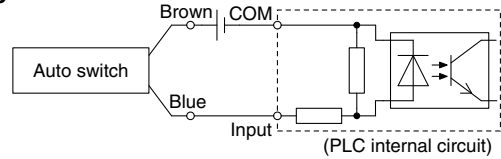

Connect according to the applicable PLC input specifications, as the connection method will vary depending on the PLC input specifications.

Examples of AND (Series) and OR (Parallel) Connections

* When using solid state auto switches, ensure the application is set up so the signals for the first 50 ms are invalid. Depending on the operating environment, the product may not operate properly.

3-wire AND connection for NPN output (Using relays)

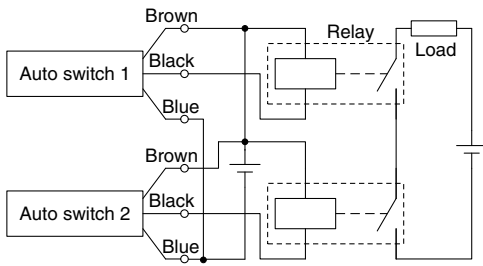

(Performed with auto switches only)

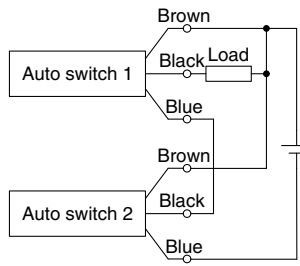

3-wire OR connection for NPN output

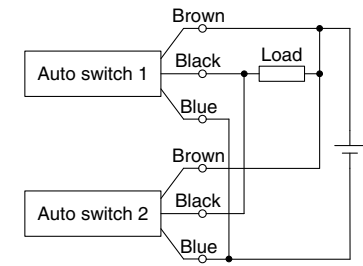

3-wire AND connection for PNP output (Using relays)

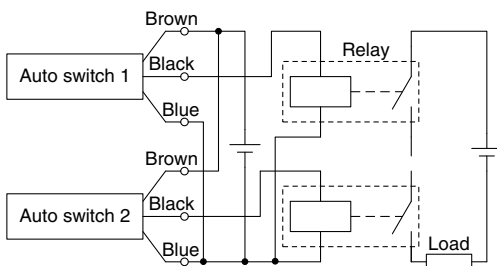

(Performed with auto switches only)

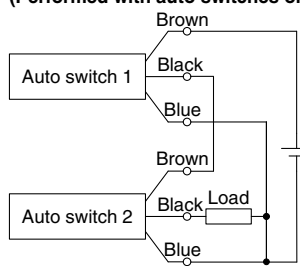

3-wire OR connection for PNP output

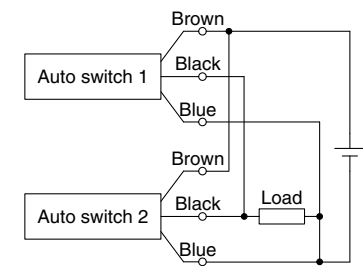

2-wire AND connection

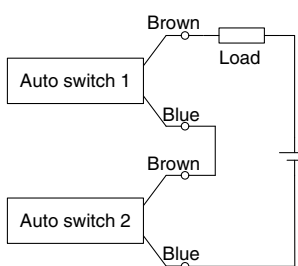

When two auto switches are connected in series, a load may malfunction because the load voltage will decline when in the ON state. The indicator lights will light up when both of the auto switches are in the ON state. Auto switches with a load voltage less than 20 V cannot be used. Please contact SMC if using AND connection for a heat-resistant solid state auto switch or a trimmer switch.

Example) Load voltage at ON
 Power supply voltage: 24 VDC
 Internal voltage drop: 4 V
 Load voltage at ON = Power supply voltage –
 Internal voltage drop x 2 pcs.
 = 24 V – 4 V x 2 pcs.
 = 16 V

2-wire OR connection

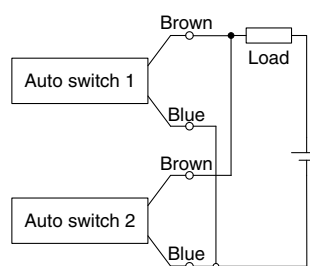

Example) Load voltage at OFF
 Leakage current: 1 mA
 Load impedance: 3 kΩ
 Load voltage at OFF = Leakage current x 2 pcs. x
 Load impedance
 = 1 mA x 2 pcs. x 3 kΩ
 = 6 V

(Solid state)
 When two auto switches are connected in parallel, malfunction may occur because the load voltage will increase when in the OFF state.

(Reed)
 Because there is no current leakage, the load voltage will not increase when turned OFF. However, depending on the number of auto switches in the ON state, the indicator lights may sometimes grow dim or not light up, due to the dispersion and reduction of the current flowing to the auto switches.

MSQ Series Made to Order

Please contact SMC for detailed dimensions, specifications, and delivery times.



1 With Interchangeable Table and Plate

Symbol
-A, -B, -C

How to Order

Standard model no. - **A**

Made to order

| | |
|----------|--------------------------------------|
| A | With interchangeable table and plate |
| B | With interchangeable table |
| C | With interchangeable plate |

* Interchangeable tables and plates can be ordered separately. For details, refer to the tables below.

* The interchangeable table and plate are assembled before shipment.

* Mounting diagram of the interchangeable table and plate
Dimensions other than those shown below are the same as those of the basic type. Refer to page 20.

Dimensions

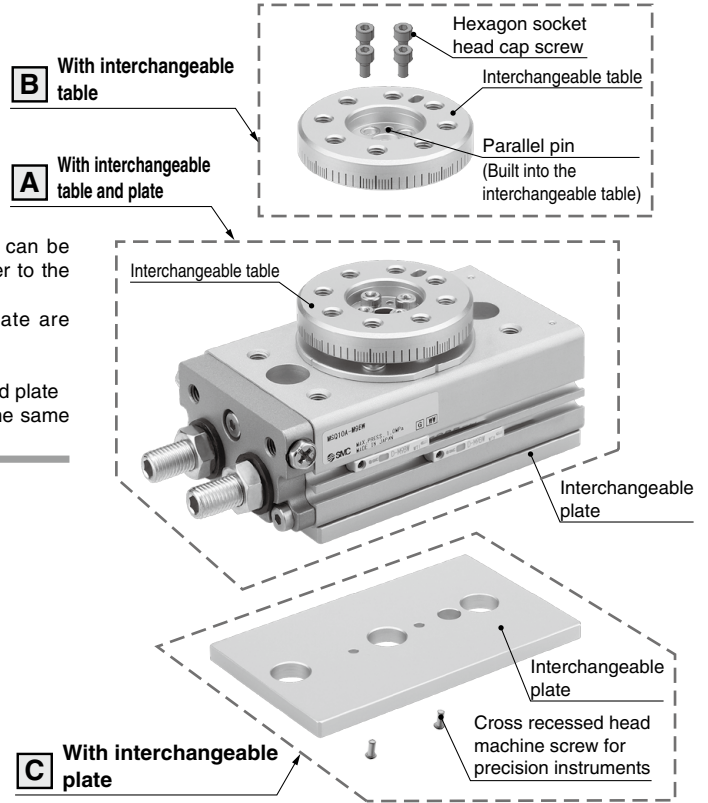
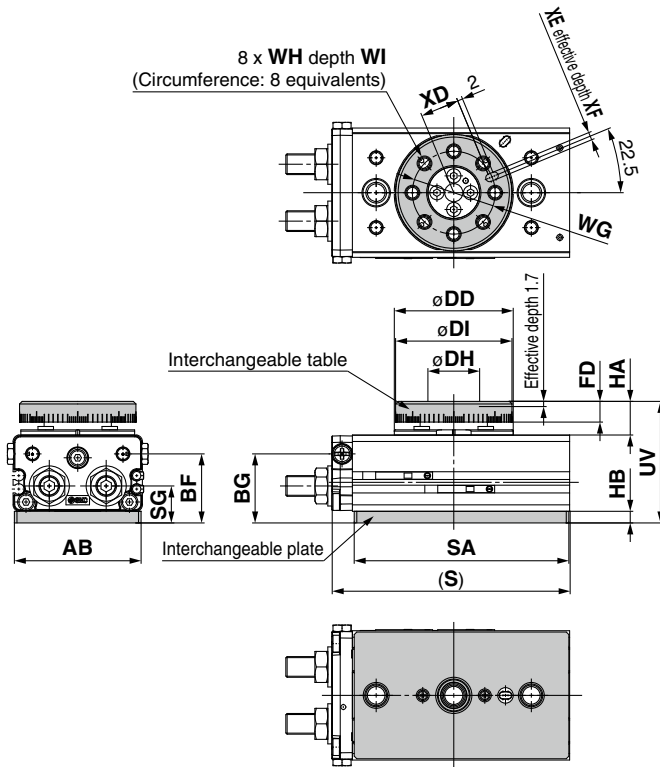

| Size | AB | SG | BF | BG | DD | DH | DI | FD | HA | HB | [mm] |
|------|----|------|------|------|------|------|------|------|----|-----|------|
| 10 | 49 | 14.3 | 26.7 | 26.7 | 46h9 | 20H9 | 45h9 | 8 | 13 | 4.5 | |
| 20 | 64 | 17.1 | 29.6 | 29.6 | 61h9 | 28H9 | 60h9 | 10 | 17 | 6 | |
| 30 | 69 | 15.8 | 32 | 33 | 67h9 | 32H9 | 65h9 | 10 | 17 | 2 | |
| 50 | 79 | 20.5 | 38 | 38 | 77h9 | 35H9 | 75h9 | 12.5 | 20 | 3 | |

| Size | S | SA | UV | WG | WH | WI | XD | XE | XF | [mm] |
|------|-----|-----|----|----|-----------|------|------|-----|-----|------|
| 10 | 92 | 83 | 47 | 32 | M5 x 0.8 | 8 | 15 | 3H9 | 3.5 | |
| 20 | 117 | 106 | 54 | 43 | M6 x 1 | 10 | 20.5 | 4H9 | 4.5 | |
| 30 | 127 | 114 | 57 | 48 | M6 x 1 | 10 | 23 | 4H9 | 4.5 | |
| 50 | 152 | 139 | 66 | 55 | M8 x 1.25 | 12.5 | 26.5 | 5H9 | 5.5 | |

Part No. of Interchangeable Parts With Interchangeable Table and Plate

| Size | Part no. | Contents Description (Qty.) |
|------|------------|---|
| 10 | P891010-50 | · Interchangeable table (1) |
| 20 | P891020-50 | · Parallel pin (1) |
| 30 | P891030-50 | · Hexagon socket head cap screw (4) |
| 50 | P891040-50 | · Interchangeable plate (1) |
| | | · Cross recessed head machine screw for precision instruments (2) |

With Interchangeable Table

| Size | Part no. | Contents Description (Qty.) |
|------|------------|-------------------------------------|
| 10 | P891010-51 | · Interchangeable table (1) |
| 20 | P891020-51 | · Parallel pin (1) |
| 30 | P891030-51 | · Hexagon socket head cap screw (4) |
| 50 | P891040-51 | |

With Interchangeable Plate

| Size | Part no. | Contents Description (Qty.) |
|------|------------|---|
| 10 | P891010-52 | |
| 20 | P891020-52 | · Interchangeable plate (1) |
| 30 | P891030-52 | · Cross recessed head machine screw for precision instruments (2) |
| 50 | P891040-52 | |

* Cushion pad type products (MSQ□A) in which the piston material has been changed to stainless steel the same as the existing product are also available separately.

* Refer to page 24 for the tightening torque of the interchangeable parts.



MSQ Series

Specific Product Precautions 1

Be sure to read this before handling the products. Refer to the back cover for safety instructions. For rotary actuator and auto switch precautions, refer to the “Handling Precautions for SMC Products” and the “Operation Manual” on the SMC website: <https://www.smcworld.com>

Speed Adjustment

Warning

1. To make a speed adjustment, gradually adjust starting from the low speed end.

If the speed adjustment is performed from the high speed end, it could damage the product. As a result, it could pose a hazard to humans or damage the machinery and equipment.

Caution

1. When operating at high speed with a large load weight, a large amount of energy is applied to the actuator and can cause damage. Calculate a correct operation time by referencing the model selection procedure on page 4.
2. Do not machine the fixed orifice of the port to enlarge its size. If the fixed orifice size is enlarged, the actuator operating speed and impact force will increase and cause damage.

Lubrication

Caution

1. Use the product without lubrication.

This product is lubricated with grease at the factory, and further lubrication will result in a failure to meet the product's specifications.

Effective Torque

Caution

1. The effective torque at the end of the rotation is half the effective torque generated during rotation. This is because one of the pistons of the double rack mechanism determines the angle by coming into contact with an adjustment bolt or a shock absorber at the rotation end.

Rotating Angle Adjustment

Caution

1. As a standard feature, the rotary table is equipped with an angle adjustment mechanism (adjustment bolt or shock absorber) that can be used to adjust the rotating angle. Refer to page 17 for the rotation direction, rotating angle, and rotating angle range examples.
2. It might be difficult to adjust the angle using a tool due to the installation condition of the product. If a special tool is required, refer to the operation manual.

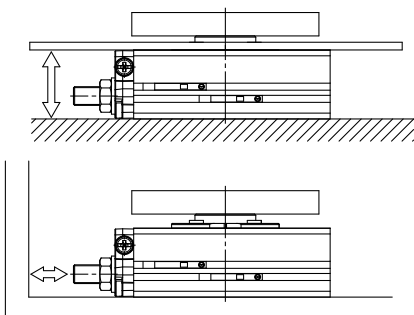

Tightening Torque

1. Tighten the adjustment bolt or the hexagon nut for setting the shock absorber with the tightening torque shown in the table below.

Hexagon nut for setting the adjustment bolt or shock absorber

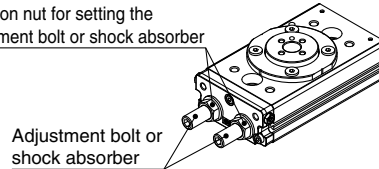

Adjustment bolt or shock absorber

| Size | Proper tightening torque [N·m] |
|------|--------------------------------|
| 10 | 1.00 to 1.67 |
| 20 | 1.88 to 3.14 |
| 30 | |
| 50 | 6.48 to 10.8 |

2. Tighten the screw for setting the interchangeable table and plate with the tightening torque shown in the table below.

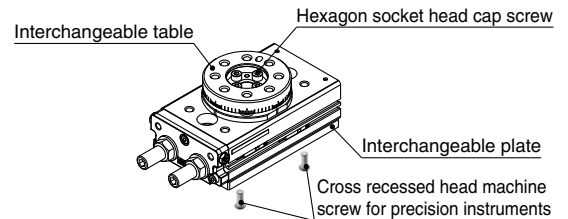

| Size | Proper tightening torque [N·m] | |
|------|---|---|
| | Screw for setting interchangeable table | Screw for setting interchangeable plate |
| 10 | 1.1 to 3.1 | 0.4 to 0.5 |
| 20 | 2.9 to 4.9 | |
| 30 | 4.9 to 6.9 | |
| 50 | 7.4 to 9.8 | |

* Refer to the operation manual for assembly procedures.

Mounting

Caution

1. Keep away from objects which are influenced by magnets.

Since this product has a built-in magnet, do not allow close contact with magnetic disks, cards, or tapes. Data may be erased.

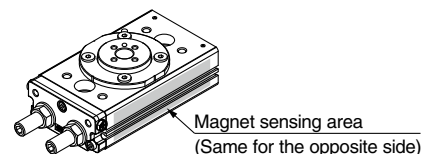

2. When using the center hole for piping, take care that the tube O.D., auto switch lead wire, etc., do not contact the mounting plate.

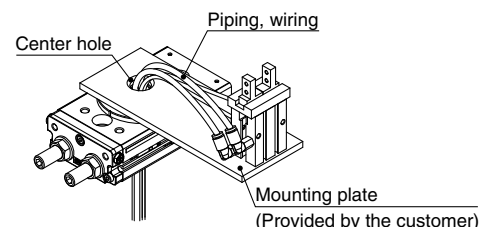



MSQ Series Specific Product Precautions 2

Be sure to read this before handling the products. Refer to the back cover for safety instructions. For rotary actuator and auto switch precautions, refer to the “Handling Precautions for SMC Products” and the “Operation Manual” on the SMC website: <https://www.smcworld.com>

Mounting

⚠ Caution

3. When mounting the body, use screws of the appropriate length.

• Basic type



1. Top mounting (Through hole)

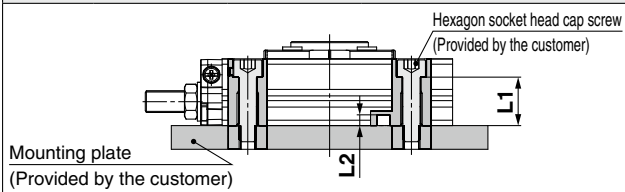

| Size | L1 | | L2 | |
|------|-----------|-------------|----------|----------------------|
| | Screw | Length [mm] | Pin [mm] | Effective depth [mm] |
| 10 | M6 x 1 | 23.5 | ø3 | 3.5 |
| 20 | M8 x 1.25 | 22.5 | ø4 | 4.5 |
| 30 | M8 x 1.25 | 29.5 | ø4 | 4.5 |
| 50 | M10 x 1.5 | 32.5 | ø5 | 5.5 |

2. Bottom mounting (Body tapped)

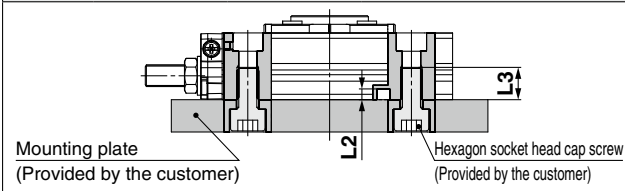

| Size | L2 | | L3 | |
|------|----------|----------------------|------------|--------------------------|
| | Pin [mm] | Effective depth [mm] | Screw | Max. screw-in depth [mm] |
| 10 | ø3 | 3.5 | M8 x 1.25 | 12 |
| 20 | ø4 | 4.5 | M10 x 1.5 | 15 |
| 30 | ø4 | 4.5 | M10 x 1.5 | 15 |
| 50 | ø5 | 5.5 | M12 x 1.75 | 18 |

3. Top mounting (Body tapped)

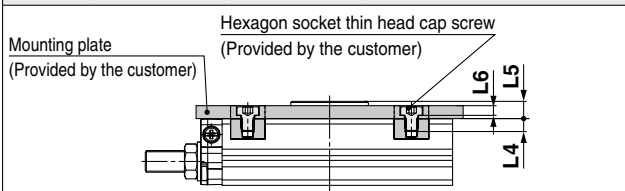

| Size | L4 | | L5 | L6 |
|------|-----------|--------------------------|-------------|------------------------|
| | Screw | Max. screw-in depth [mm] | Height [mm] | Counterbore depth [mm] |
| 10 | M5 x 0.8 | 6 | 6 | 3.9 |
| 20 | M6 x 1 | 6 | 8 | 4.5 |
| 30 | M6 x 1 | 6 | 8 | 4.5 |
| 50 | M8 x 1.25 | 8 | 8.5 | 5.6 |

• With interchangeable plate

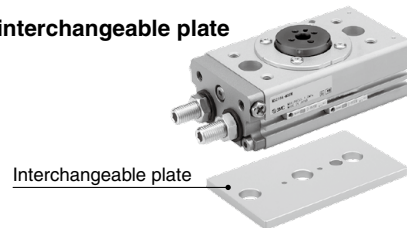

4. Top mounting (Through hole)

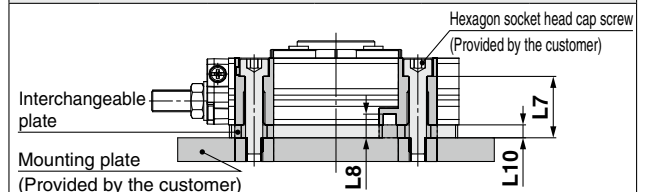

| Size | L7 | | L8 | | L10 |
|------|-----------|-------------|----------|--------------|----------------------|
| | Screw | Length [mm] | Pin [mm] | Depth*1 [mm] | Plate thickness [mm] |
| 10 | M6 x 1 | 28 | ø3 | 8 | 4.5 |
| 20 | M8 x 1.25 | 28.5 | ø4 | 10.5 | 6 |
| 30 | M8 x 1.25 | 31.5 | ø4 | 6.5 | 2 |
| 50 | M10 x 1.5 | 35.5 | ø5 | 8.5 | 3 |

*1 The effective depth of the pin is the depth obtained by subtracting the plate thickness (L10) from the L8 depth.

* Refer to page 24 for the tightening torque of the interchangeable parts.

5. Bottom mounting (Body tapped)

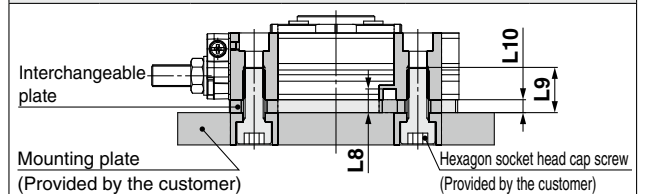

| Size | L8 | | L9 | | L10 |
|------|----------|--------------|------------|--------------------------|----------------------|
| | Pin [mm] | Depth*1 [mm] | Screw | Max. screw-in depth [mm] | Plate thickness [mm] |
| 10 | ø3 | 8 | M8 x 1.25 | 16.5 | 4.5 |
| 20 | ø4 | 10.5 | M10 x 1.5 | 21 | 6 |
| 30 | ø4 | 6.5 | M10 x 1.5 | 17 | 2 |
| 50 | ø5 | 8.5 | M12 x 1.75 | 21 | 3 |

*1 The effective depth of the pin is the depth obtained by subtracting the plate thickness (L10) from the L8 depth.

* Refer to page 24 for the tightening torque of the interchangeable parts.



MSQ Series

Specific Product Precautions 3

Be sure to read this before handling the products. Refer to the back cover for safety instructions. For rotary actuator and auto switch precautions, refer to the “Handling Precautions for SMC Products” and the “Operation Manual” on the SMC website: <https://www.smcworld.com>

Shock Absorber

⚠ Caution

1. Never rotate the bottom screw of the shock absorber. (It is not an adjustment screw.) This may cause oil leakage.

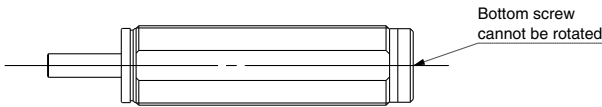

2. Products with shock absorber are not designed to smooth stop but to absorb the kinetic energy of the load. If the load has to be stopped smoothly, a shock absorber of the optimum size meeting the operating conditions must be installed external to the equipment.
3. Shock absorbers are consumable parts.
When a decrease in energy absorption capacity is noticed, it must be replaced.

With internal shock absorber

| Size | Shock absorber model |
|------|----------------------|
| 10 | RBA0805-X692 |
| 20 | RBA1006-X692 |
| 30 | |
| 50 | RBA1411-X692 |

Service Life and Replacement Period of Shock Absorber

⚠ Caution

1. Allowable operation time under the specifications set in this catalog is 1 million.

* Specified service life (suitable replacement period) is the value at room temperature (20 to 25°C). The period may vary depending on the temperature and other conditions. In some cases the absorber may need to be replaced before the allowable operation time above.

Safety Instructions

These safety instructions are intended to prevent hazardous situations and/or equipment damage. These instructions indicate the level of potential hazard with the labels of “**Caution**,” “**Warning**” or “**Danger**.” They are all important notes for safety and must be followed in addition to International Standards (ISO/IEC)*1), and other safety regulations.

 **Caution:** **Caution** indicates a hazard with a low level of risk which, if not avoided, could result in minor or moderate injury.

 **Warning:** **Warning** indicates a hazard with a medium level of risk which, if not avoided, could result in death or serious injury.

 **Danger:** **Danger** indicates a hazard with a high level of risk which, if not avoided, will result in death or serious injury.

*1) ISO 4414: Pneumatic fluid power – General rules relating to systems.
ISO 4413: Hydraulic fluid power – General rules relating to systems.
IEC 60204-1: Safety of machinery – Electrical equipment of machines.
(Part 1: General requirements)
ISO 10218-1: Manipulating industrial robots – Safety.
etc.

Warning

1. The compatibility of the product is the responsibility of the person who designs the equipment or decides its specifications.

Since the product specified here is used under various operating conditions, its compatibility with specific equipment must be decided by the person who designs the equipment or decides its specifications based on necessary analysis and test results. The expected performance and safety assurance of the equipment will be the responsibility of the person who has determined its compatibility with the product. This person should also continuously review all specifications of the product referring to its latest catalog information, with a view to giving due consideration to any possibility of equipment failure when configuring the equipment.

2. Only personnel with appropriate training should operate machinery and equipment.

The product specified here may become unsafe if handled incorrectly. The assembly, operation and maintenance of machines or equipment including our products must be performed by an operator who is appropriately trained and experienced.

3. Do not service or attempt to remove product and machinery/equipment until safety is confirmed.

1. The inspection and maintenance of machinery/equipment should only be performed after measures to prevent falling or runaway of the driven objects have been confirmed.
2. When the product is to be removed, confirm that the safety measures as mentioned above are implemented and the power from any appropriate source is cut, and read and understand the specific product precautions of all relevant products carefully.
3. Before machinery/equipment is restarted, take measures to prevent unexpected operation and malfunction.

4. Contact SMC beforehand and take special consideration of safety measures if the product is to be used in any of the following conditions.

1. Conditions and environments outside of the given specifications, or use outdoors or in a place exposed to direct sunlight.
2. Installation on equipment in conjunction with atomic energy, railways, air navigation, space, shipping, vehicles, military, medical treatment, combustion and recreation, or equipment in contact with food and beverages, emergency stop circuits, clutch and brake circuits in press applications, safety equipment or other applications unsuitable for the standard specifications described in the product catalog.
3. An application which could have negative effects on people, property, or animals requiring special safety analysis.
4. Use in an interlock circuit, which requires the provision of double interlock for possible failure by using a mechanical protective function, and periodical checks to confirm proper operation.

Caution

1. The product is provided for use in manufacturing industries.

The product herein described is basically provided for peaceful use in manufacturing industries.
If considering using the product in other industries, consult SMC beforehand and exchange specifications or a contract if necessary.
If anything is unclear, contact your nearest sales branch.

Limited warranty and Disclaimer/ Compliance Requirements

The product used is subject to the following “Limited warranty and Disclaimer” and “Compliance Requirements”.

Read and accept them before using the product.

Limited warranty and Disclaimer

1. The warranty period of the product is 1 year in service or 1.5 years after the product is delivered, whichever is first.*2)
Also, the product may have specified durability, running distance or replacement parts. Please consult your nearest sales branch.
2. For any failure or damage reported within the warranty period which is clearly our responsibility, a replacement product or necessary parts will be provided.
This limited warranty applies only to our product independently, and not to any other damage incurred due to the failure of the product.
3. Prior to using SMC products, please read and understand the warranty terms and disclaimers noted in the specified catalog for the particular products.

*2) Vacuum pads are excluded from this 1 year warranty.

A vacuum pad is a consumable part, so it is warranted for a year after it is delivered.
Also, even within the warranty period, the wear of a product due to the use of the vacuum pad or failure due to the deterioration of rubber material are not covered by the limited warranty.

Compliance Requirements

1. The use of SMC products with production equipment for the manufacture of weapons of mass destruction (WMD) or any other weapon is strictly prohibited.
2. The exports of SMC products or technology from one country to another are governed by the relevant security laws and regulations of the countries involved in the transaction. Prior to the shipment of a SMC product to another country, assure that all local rules governing that export are known and followed.

Caution

SMC products are not intended for use as instruments for legal metrology.

Measurement instruments that SMC manufactures or sells have not been qualified by type approval tests relevant to the metrology (measurement) laws of each country. Therefore, SMC products cannot be used for business or certification ordained by the metrology (measurement) laws of each country.

Safety Instructions

Be sure to read the “Handling Precautions for SMC Products” (M-E03-3) and “Operation Manual” before use.